



CITY

7638



28

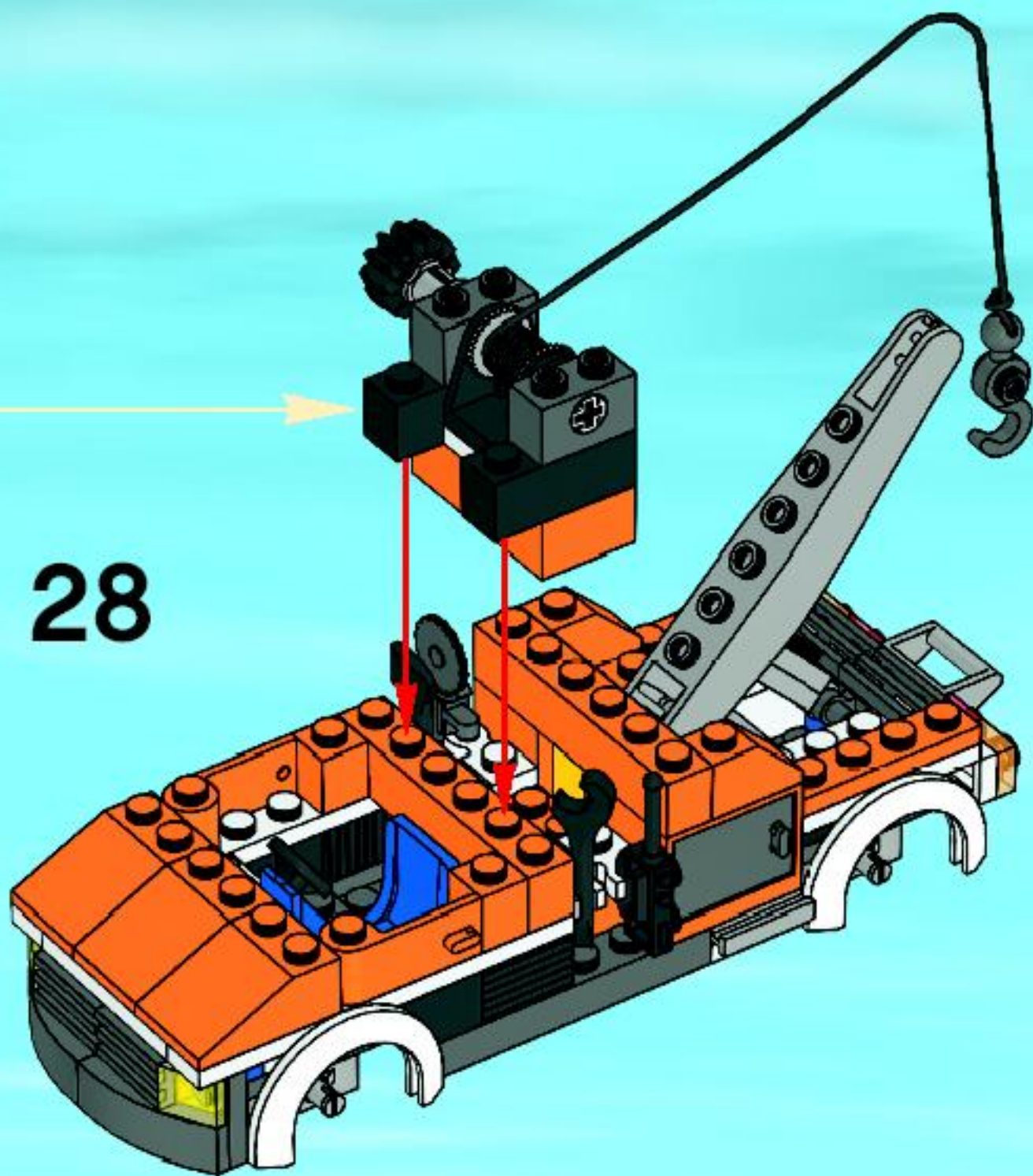

1

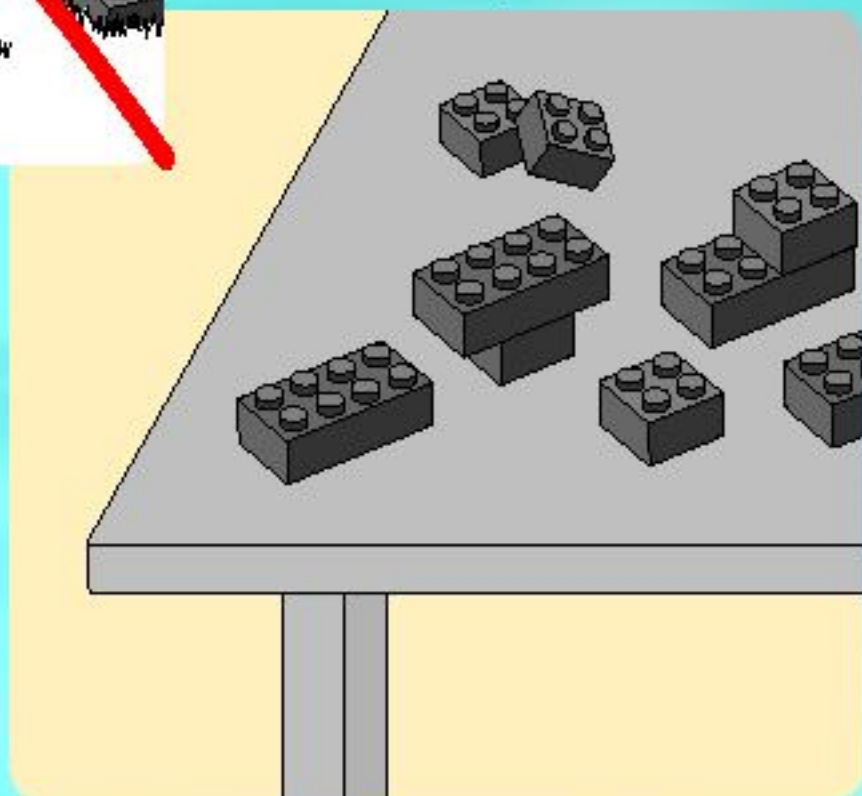

2

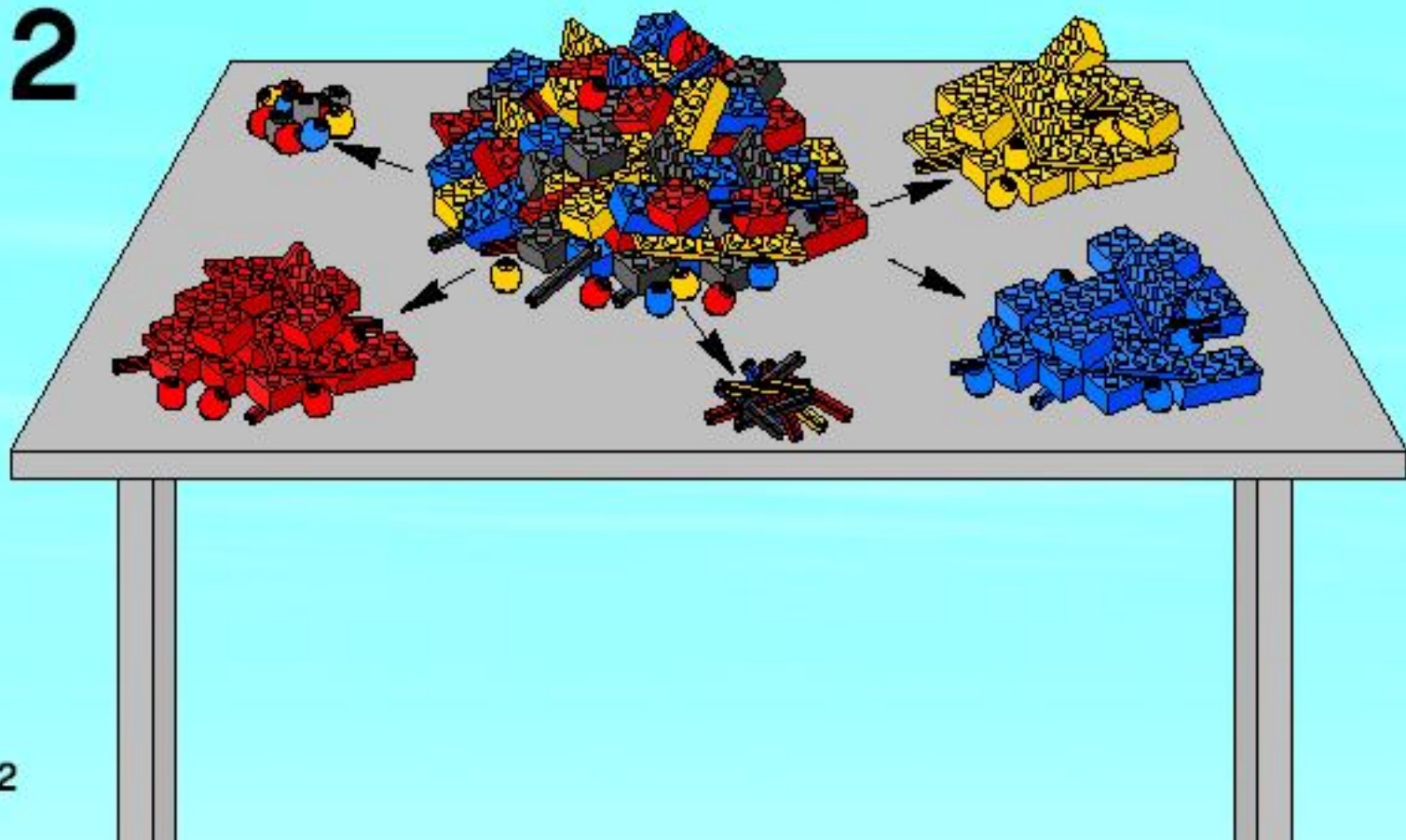

3

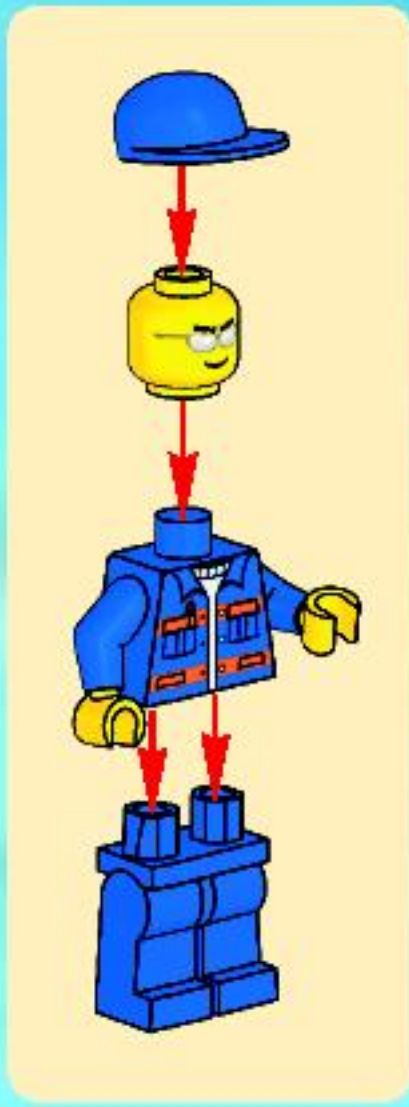

1

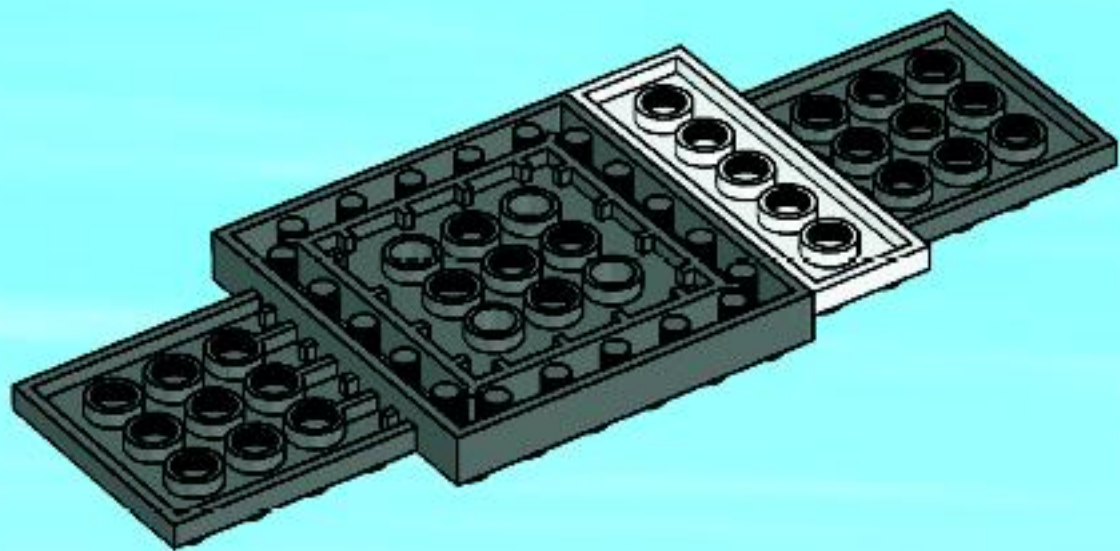

2

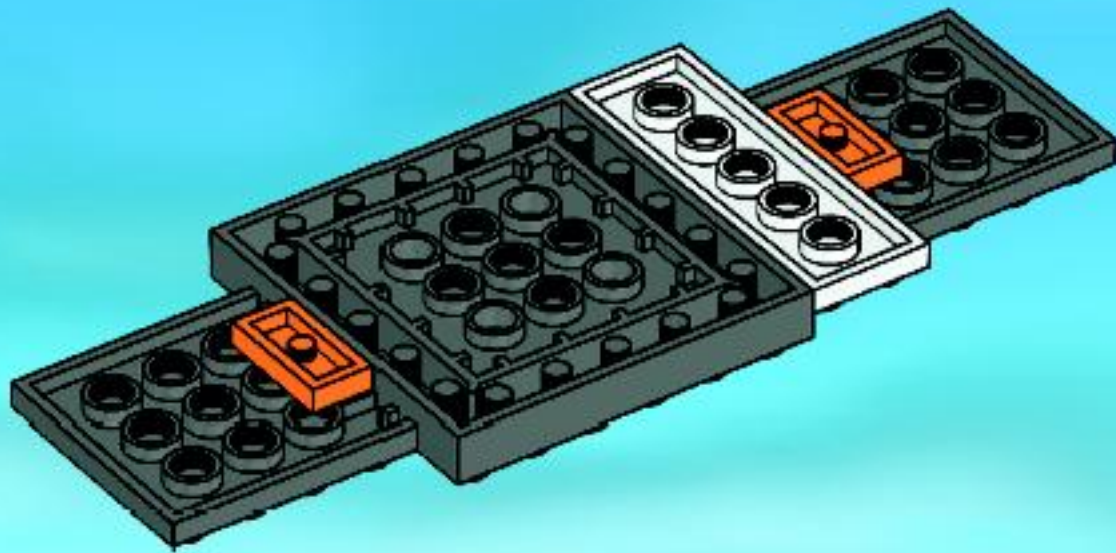

3

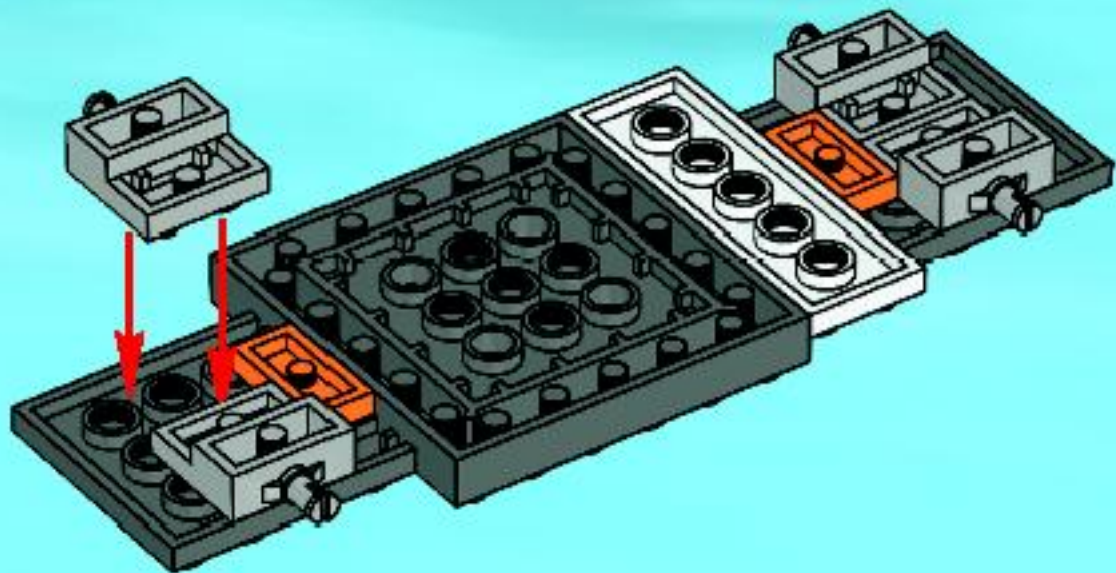

4

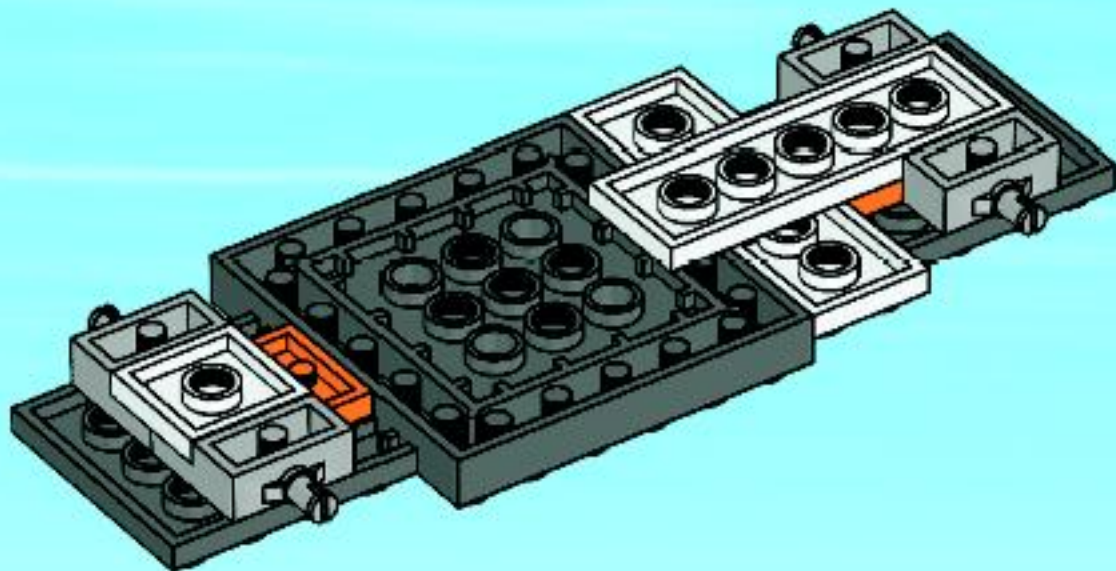

5

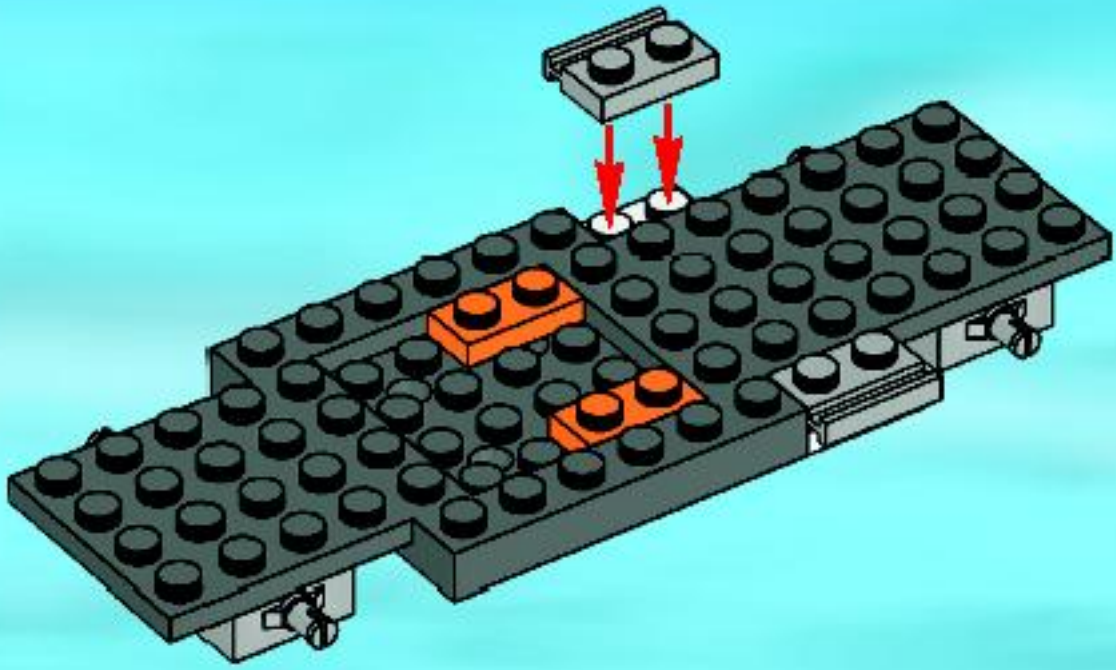

6

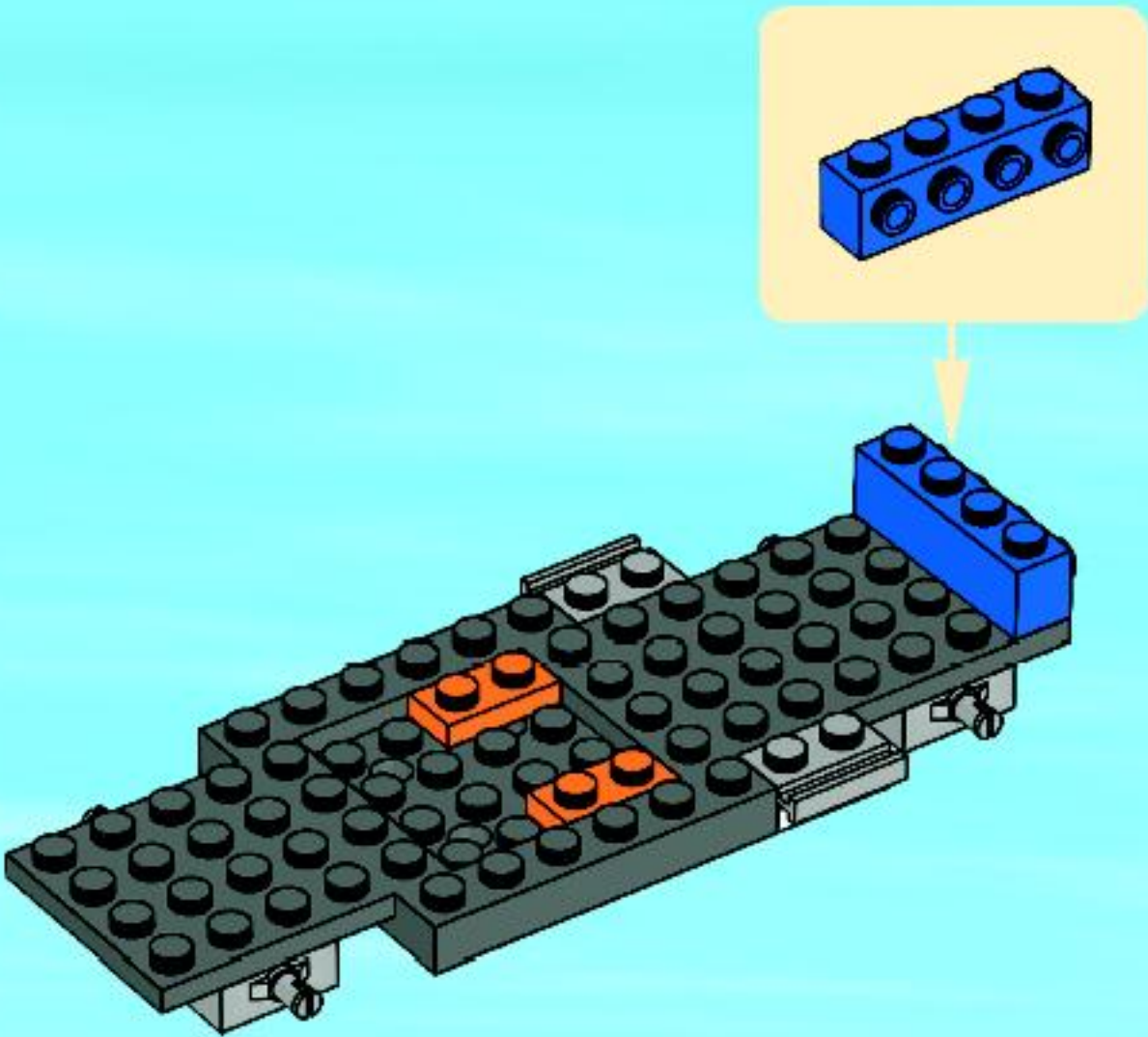

7

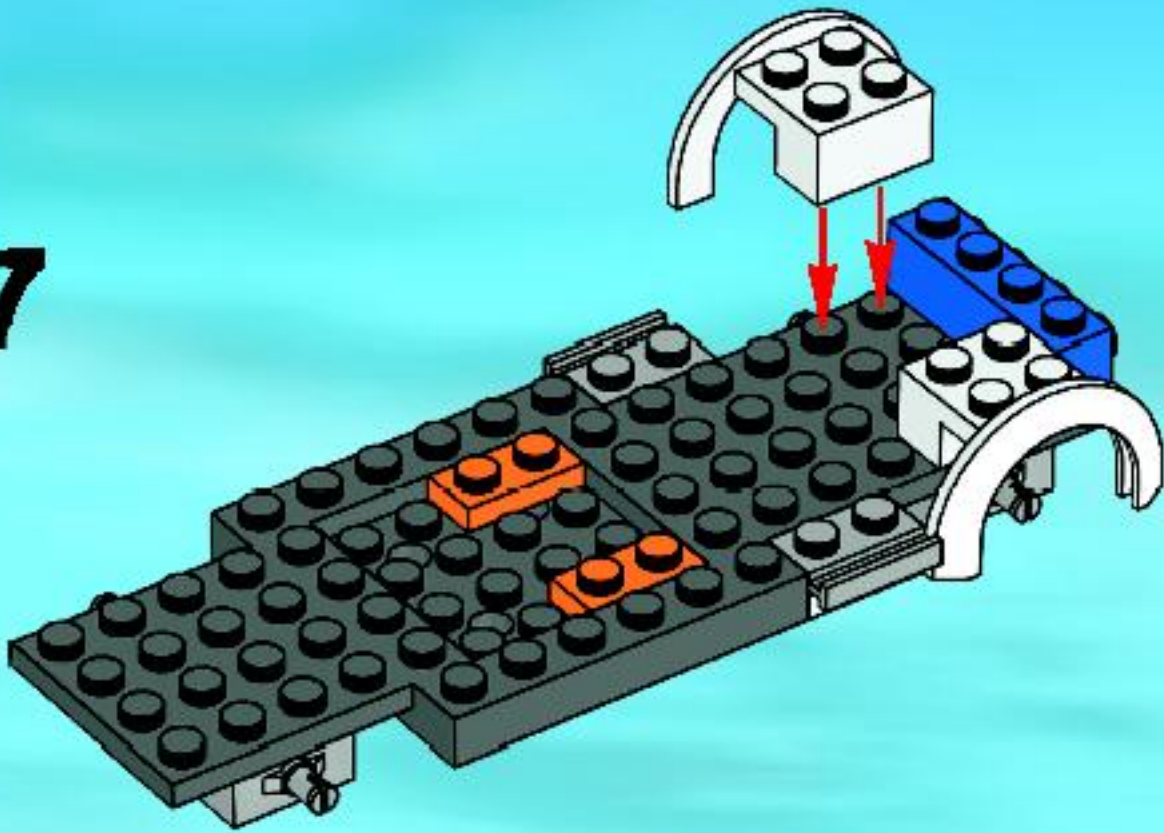

8

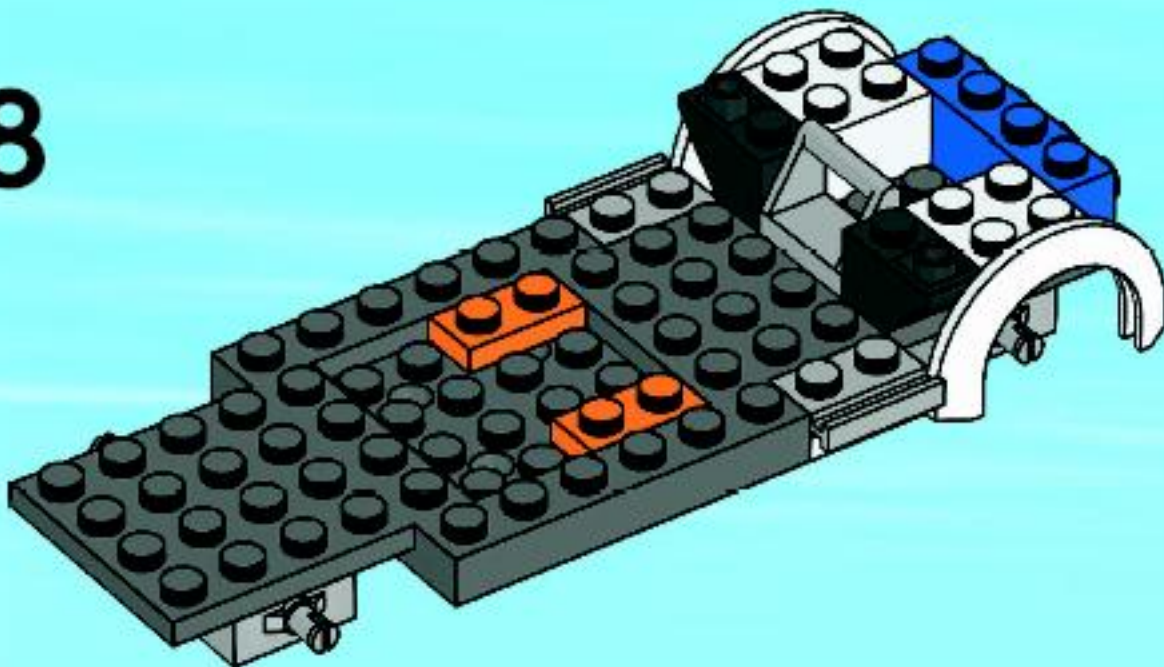

9

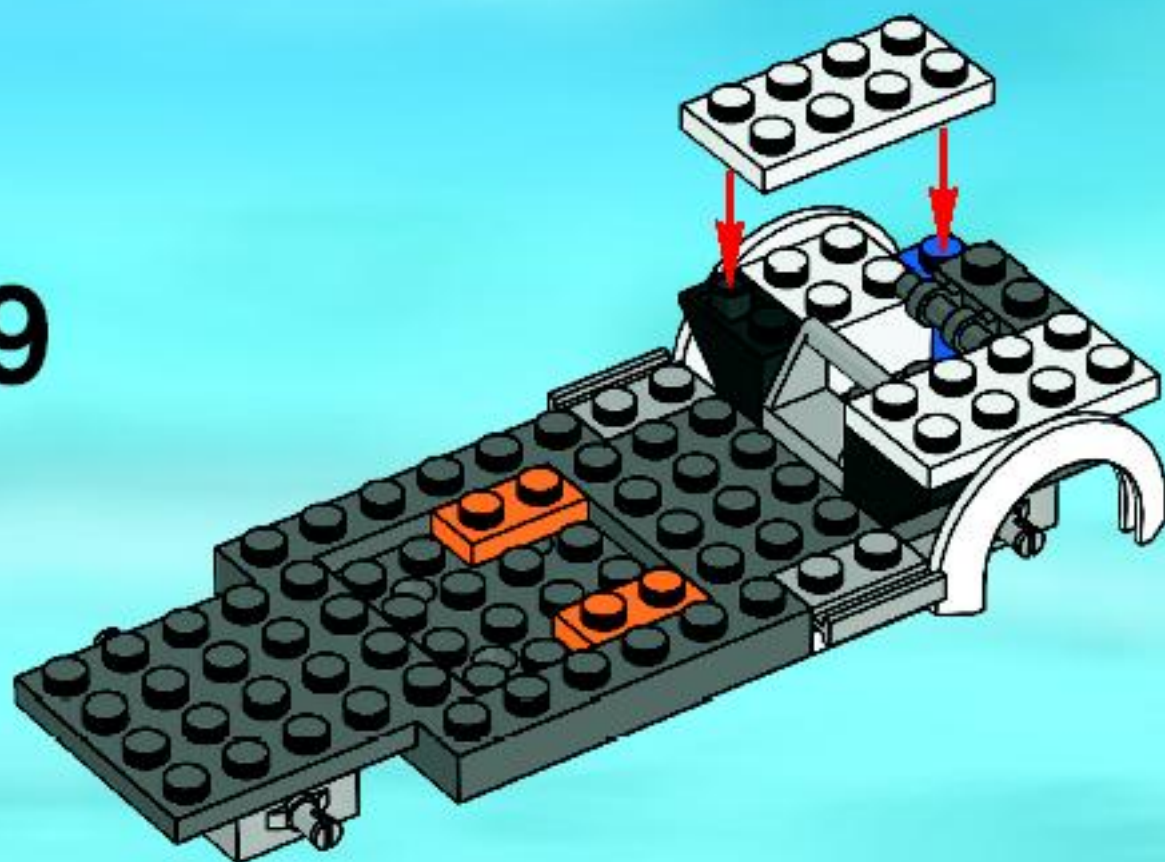

10

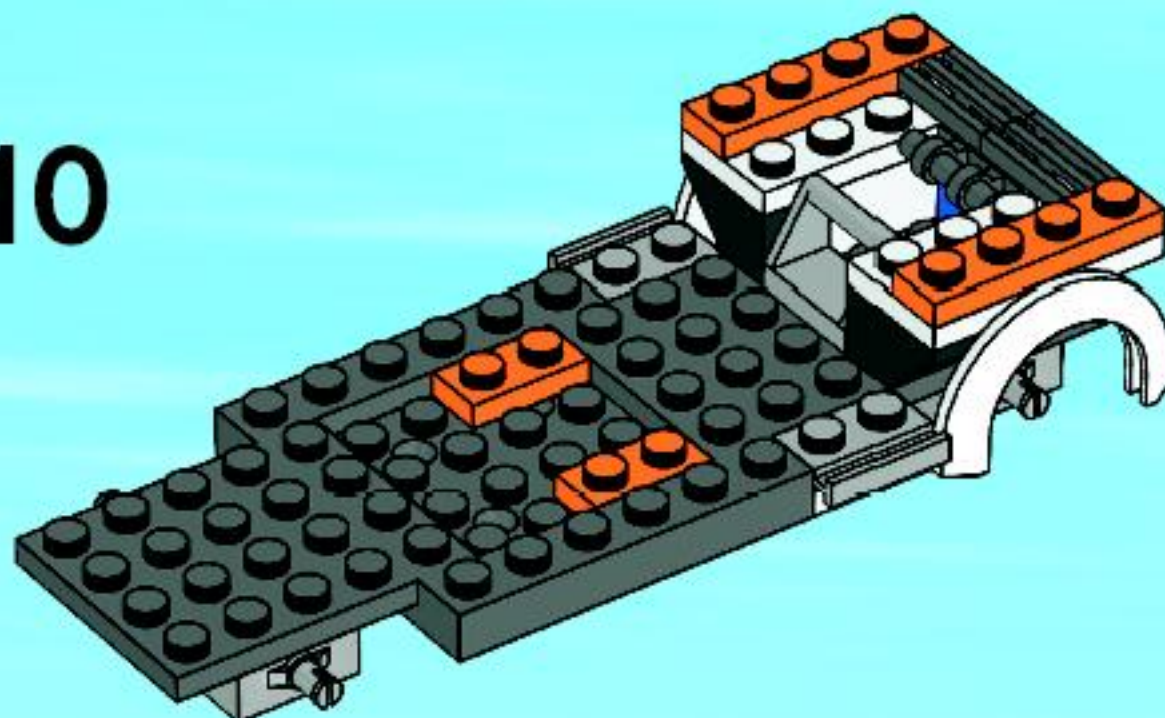



11

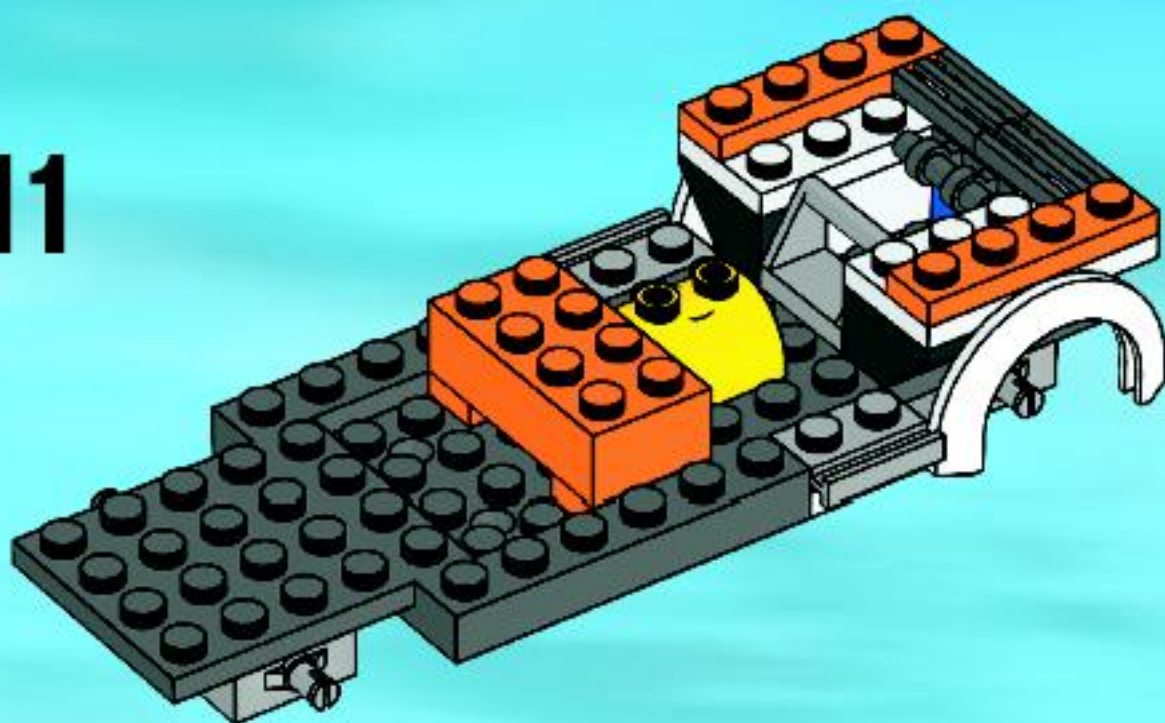

12

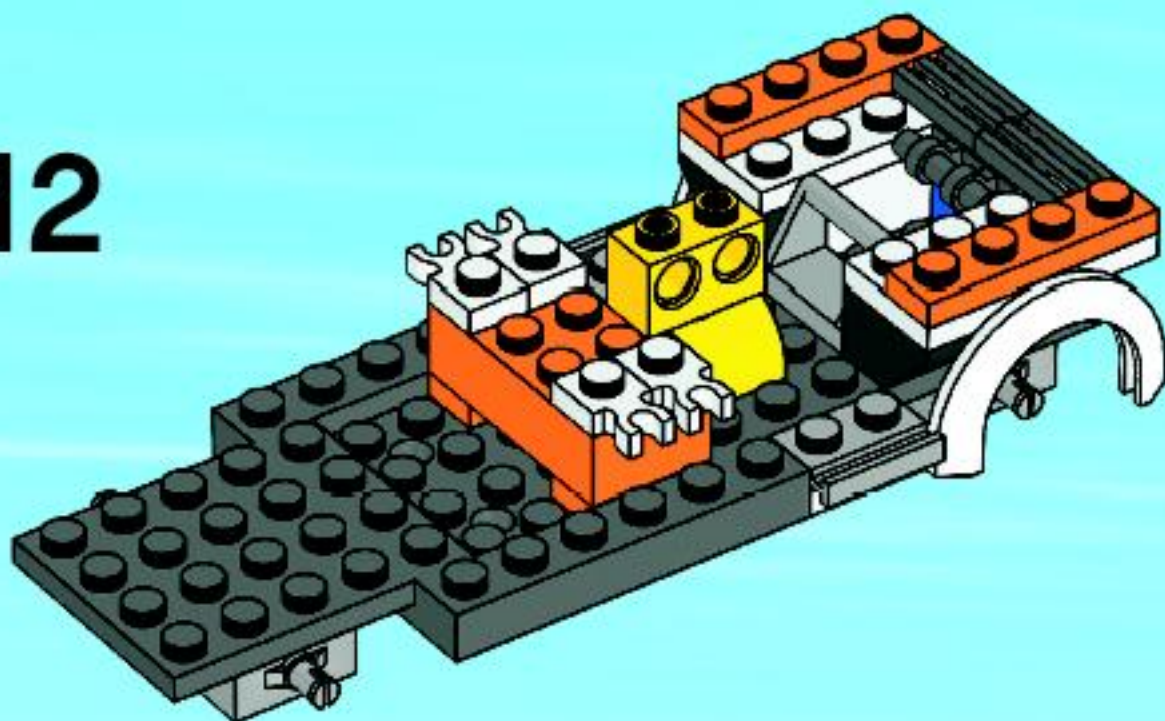

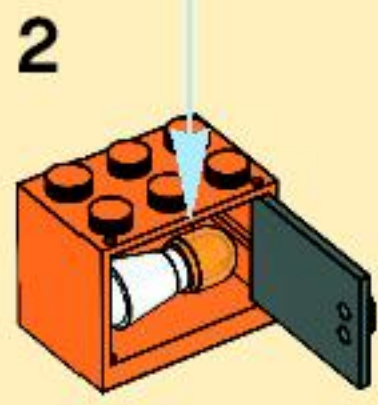
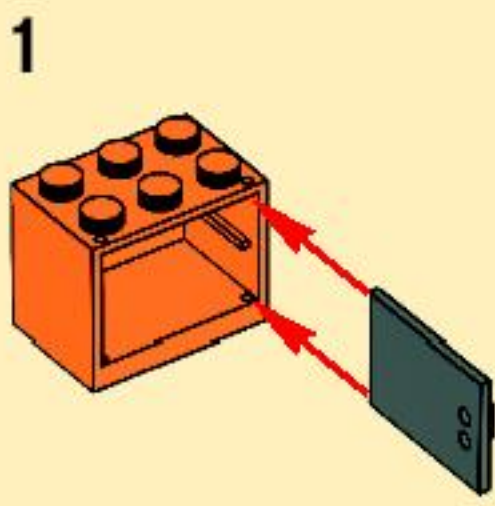
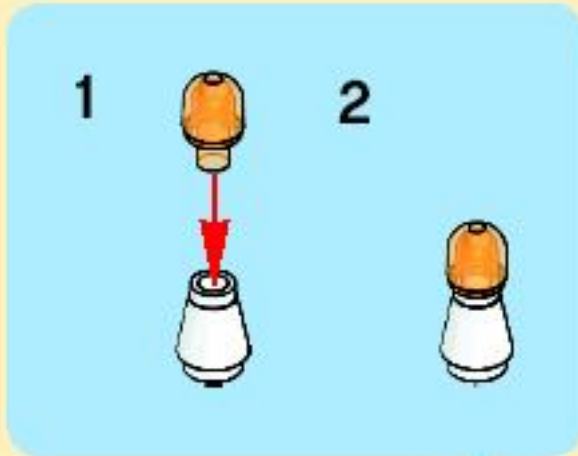

13

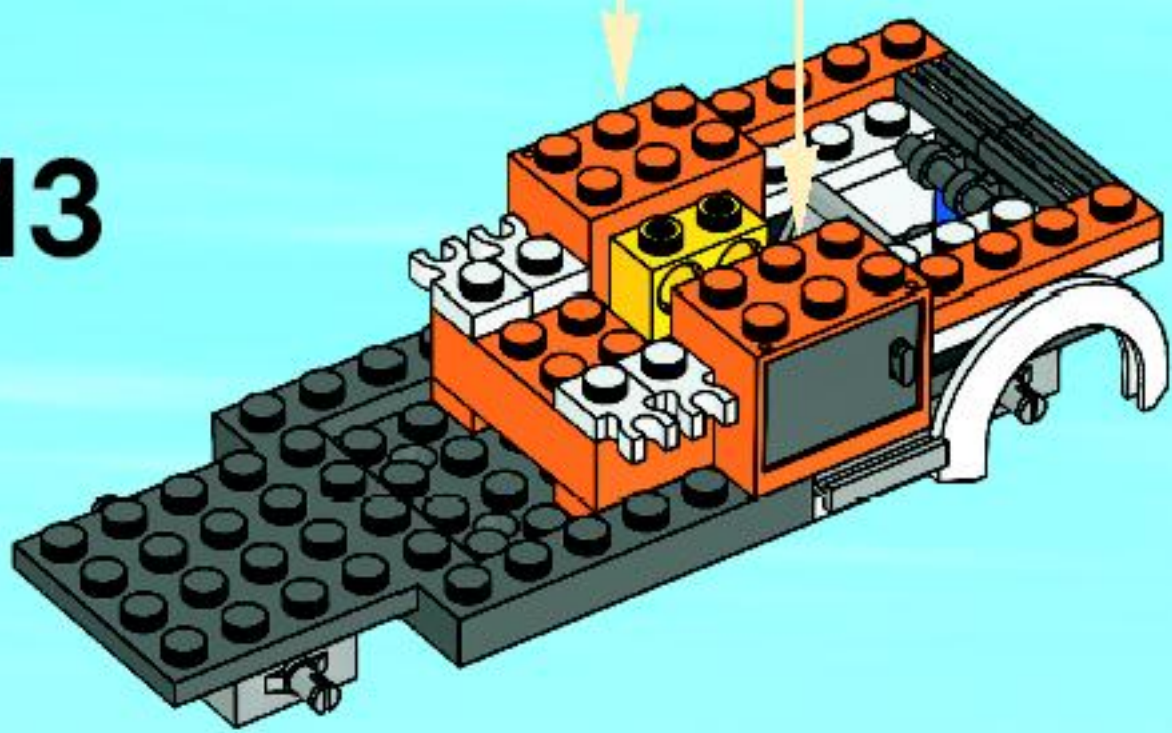





1

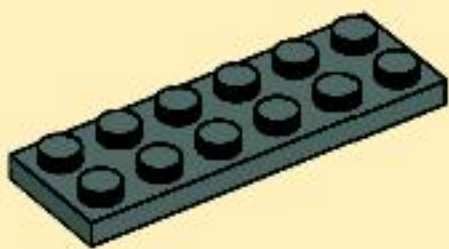

3

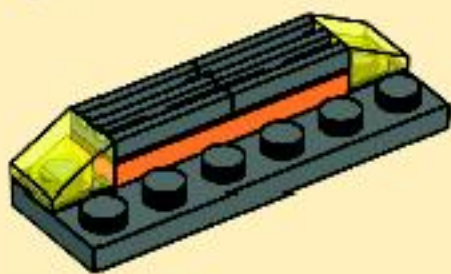

2

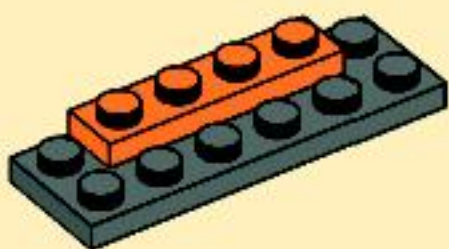

4

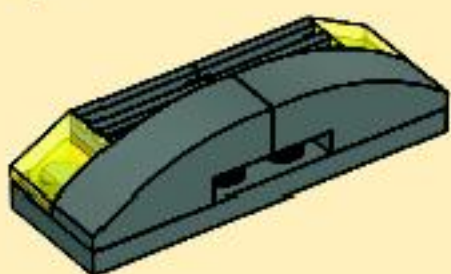

17

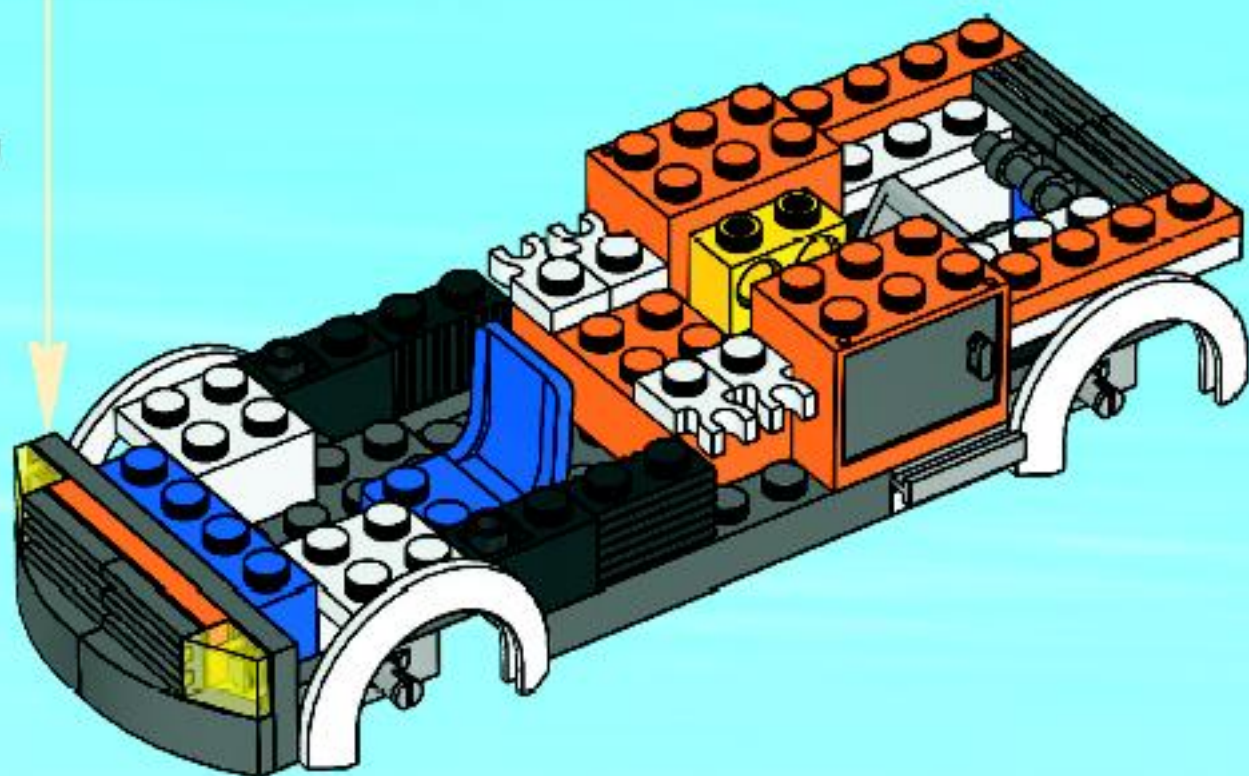

18

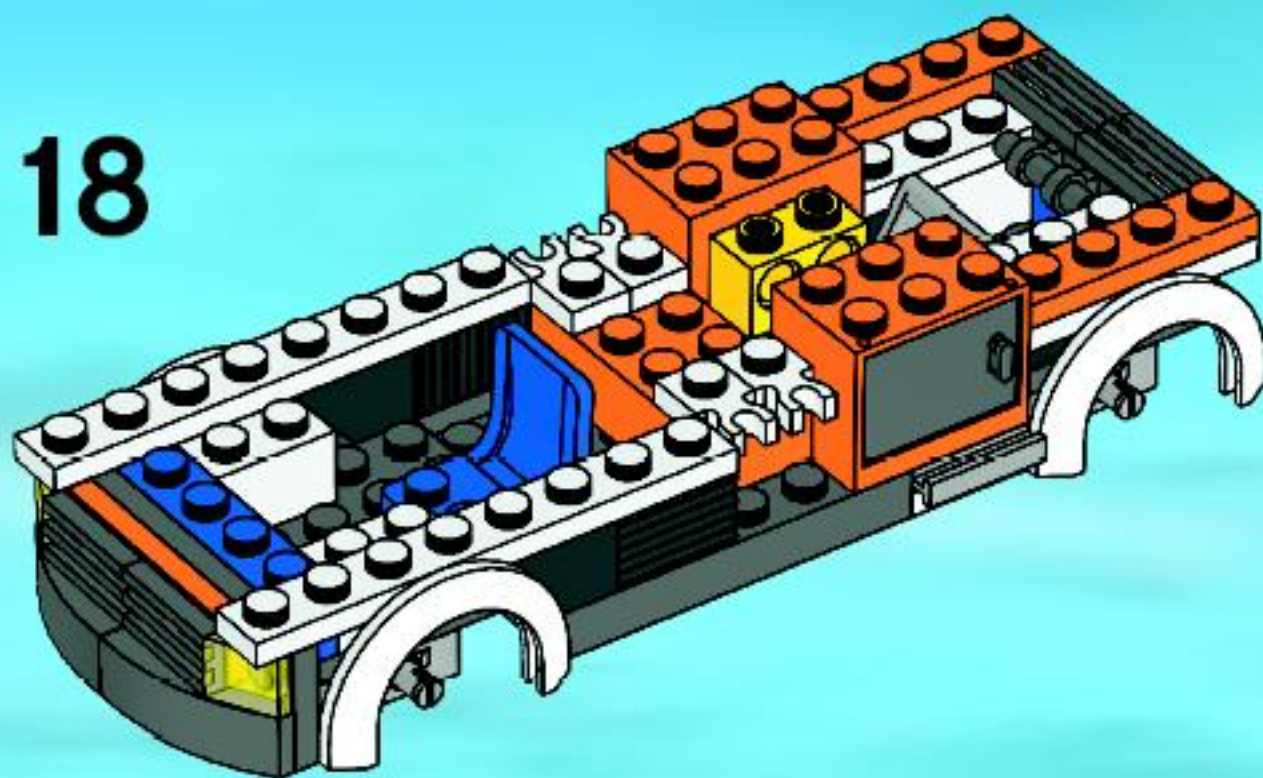

19

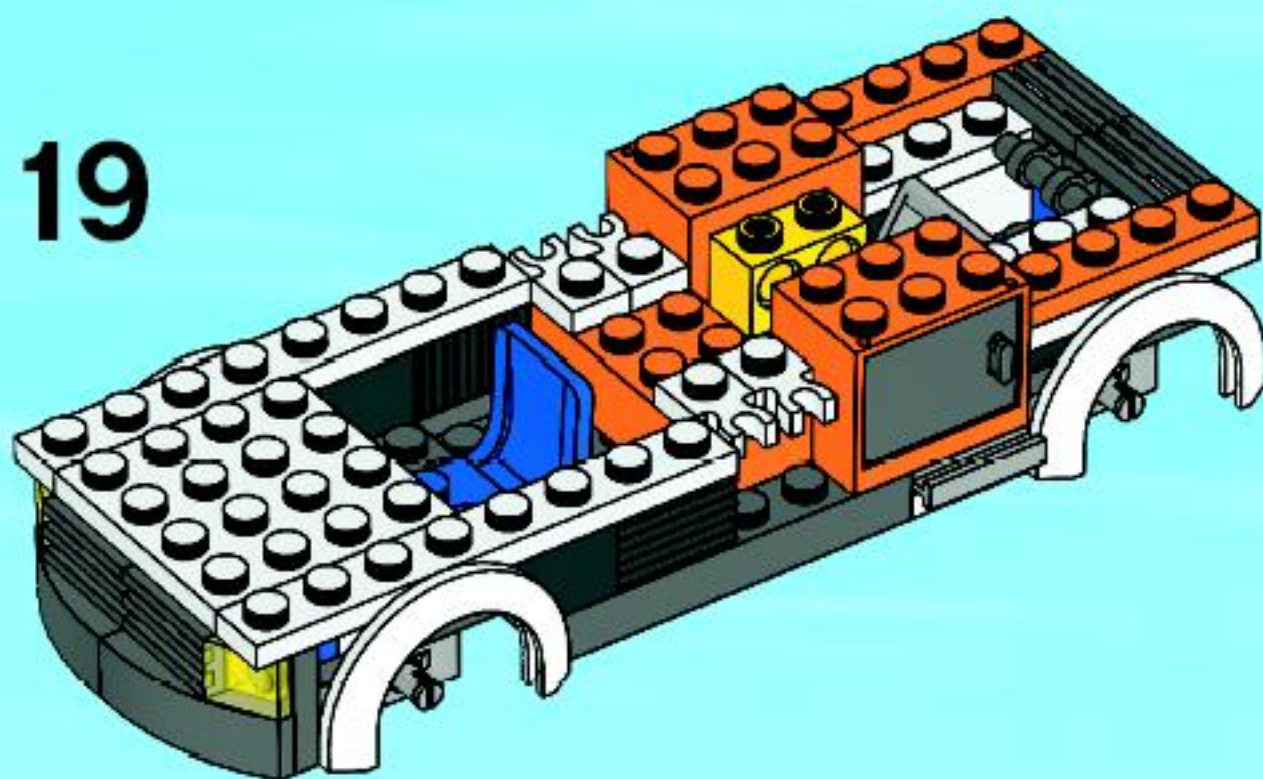

20

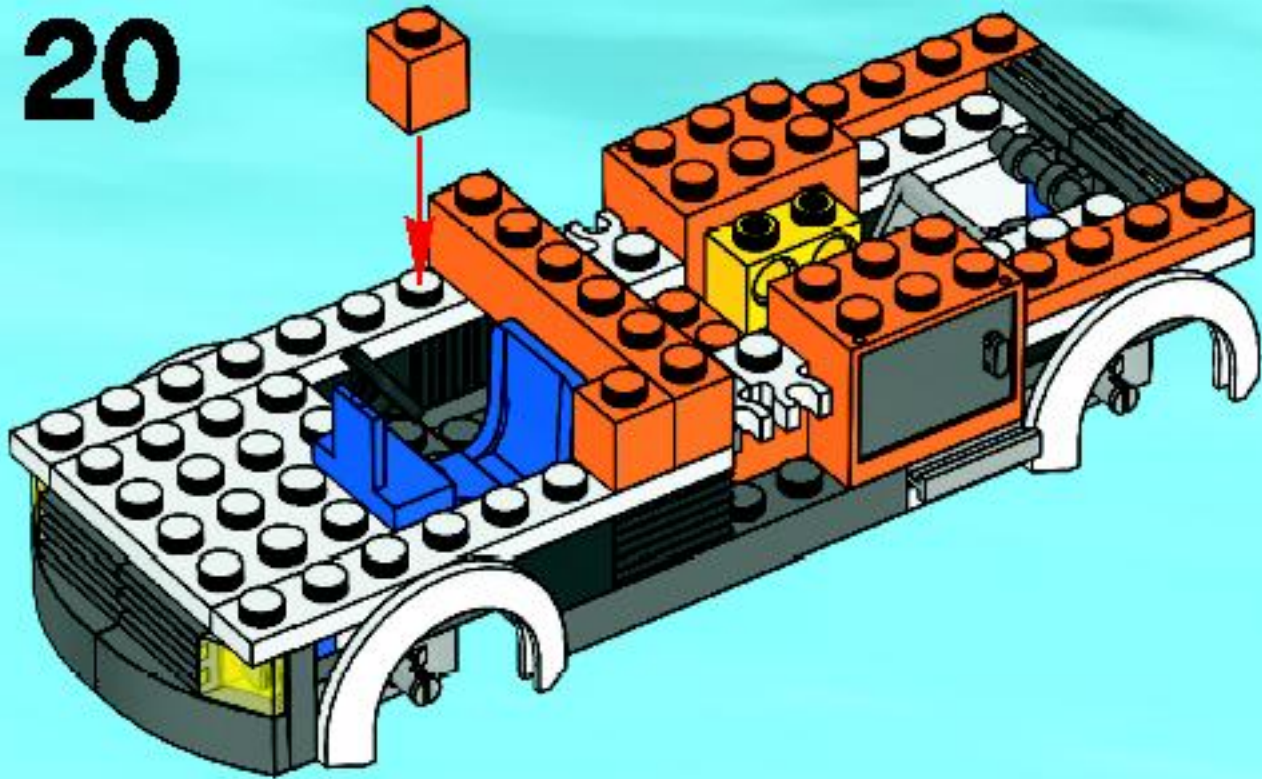

21

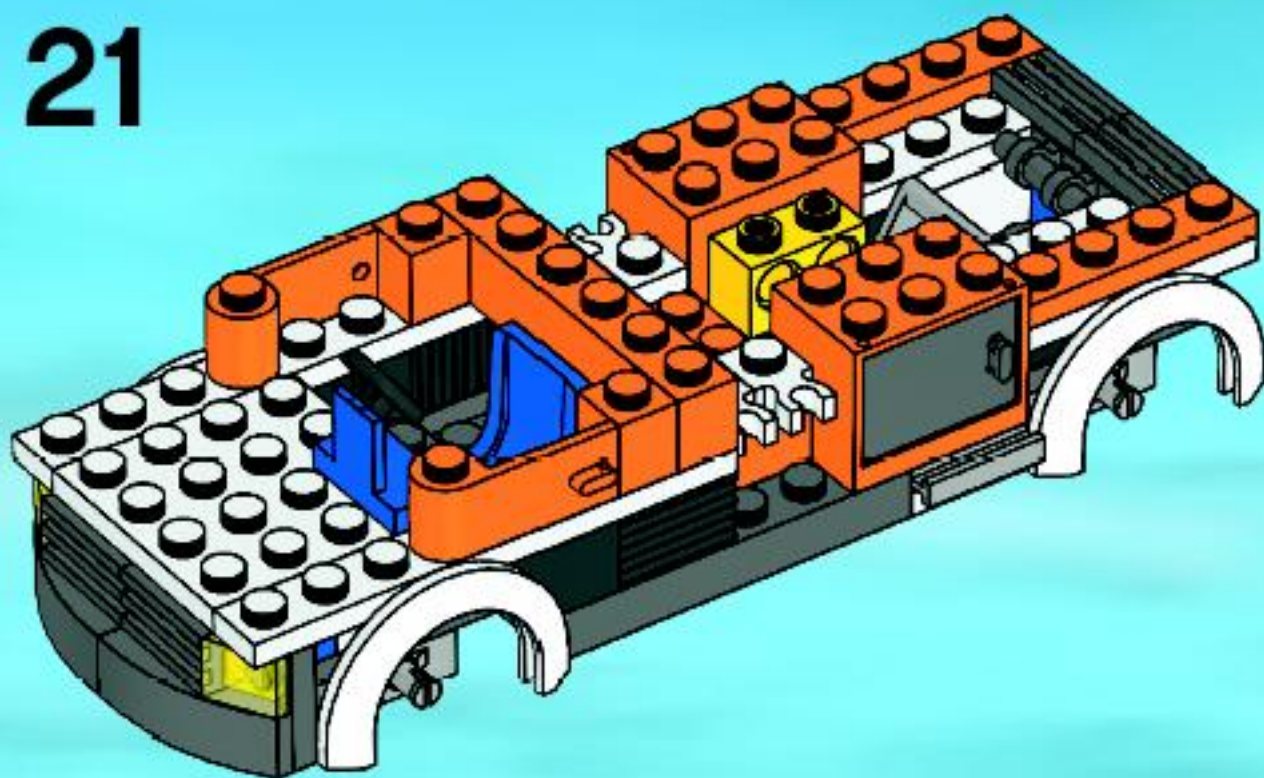

22

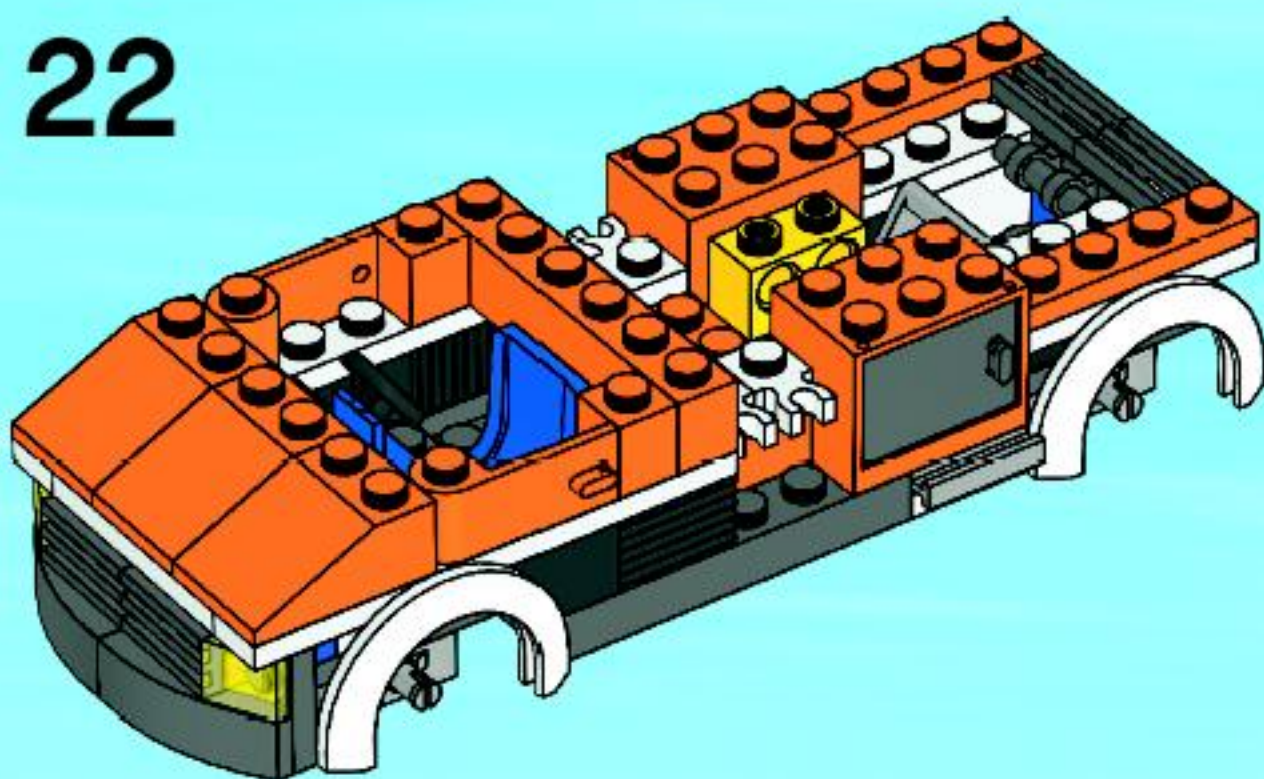



23

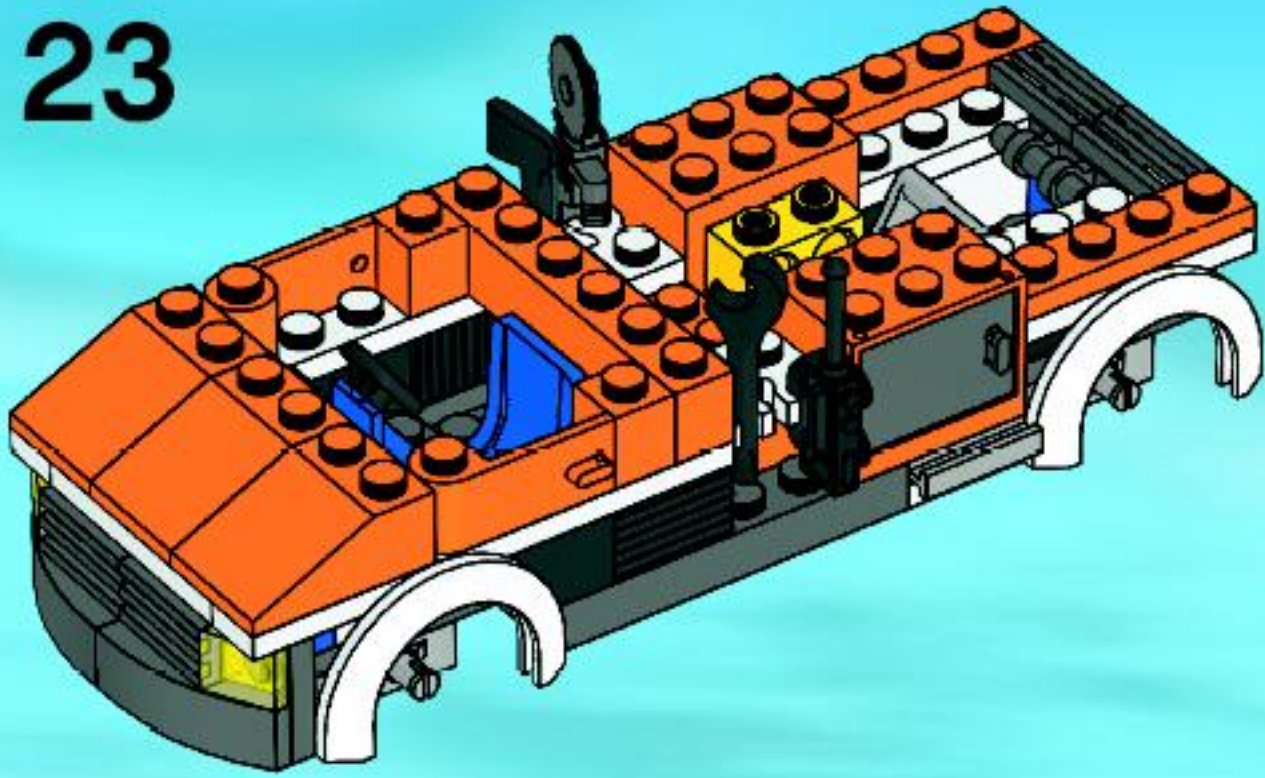

24

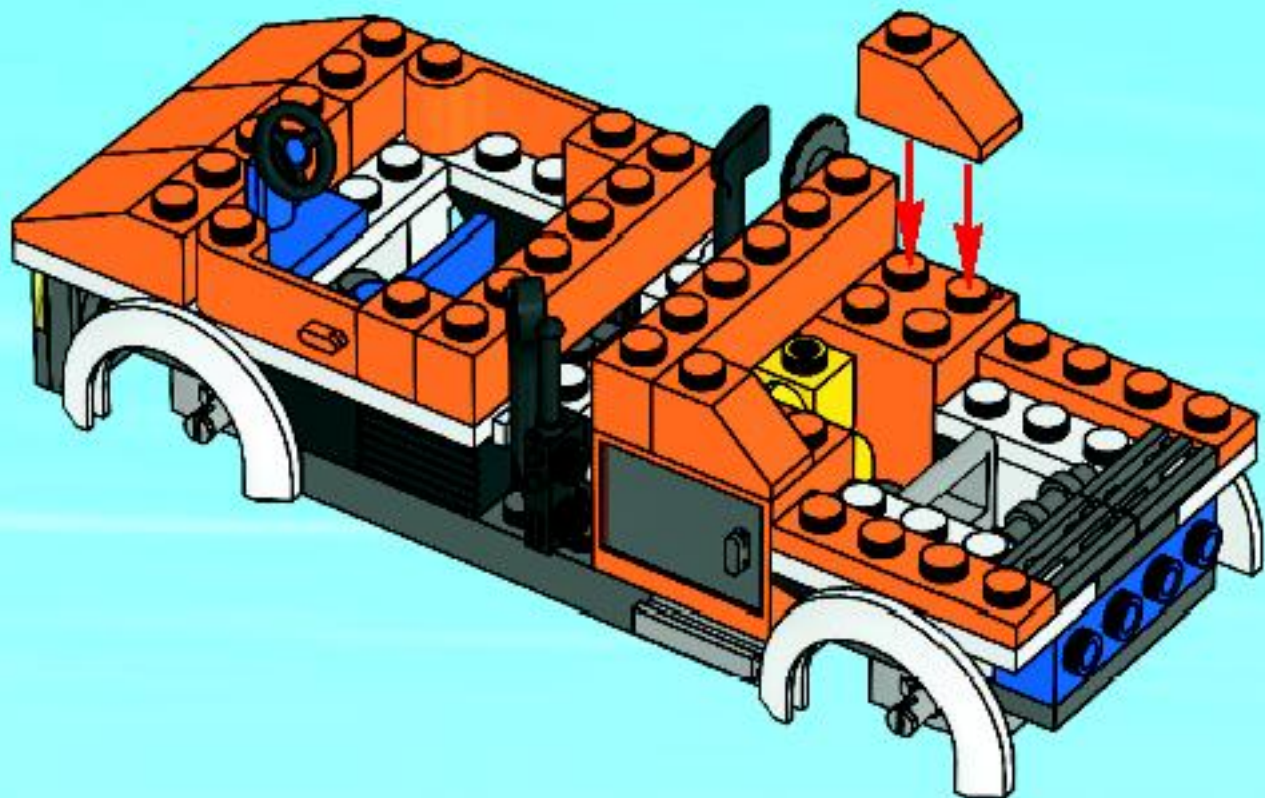

25

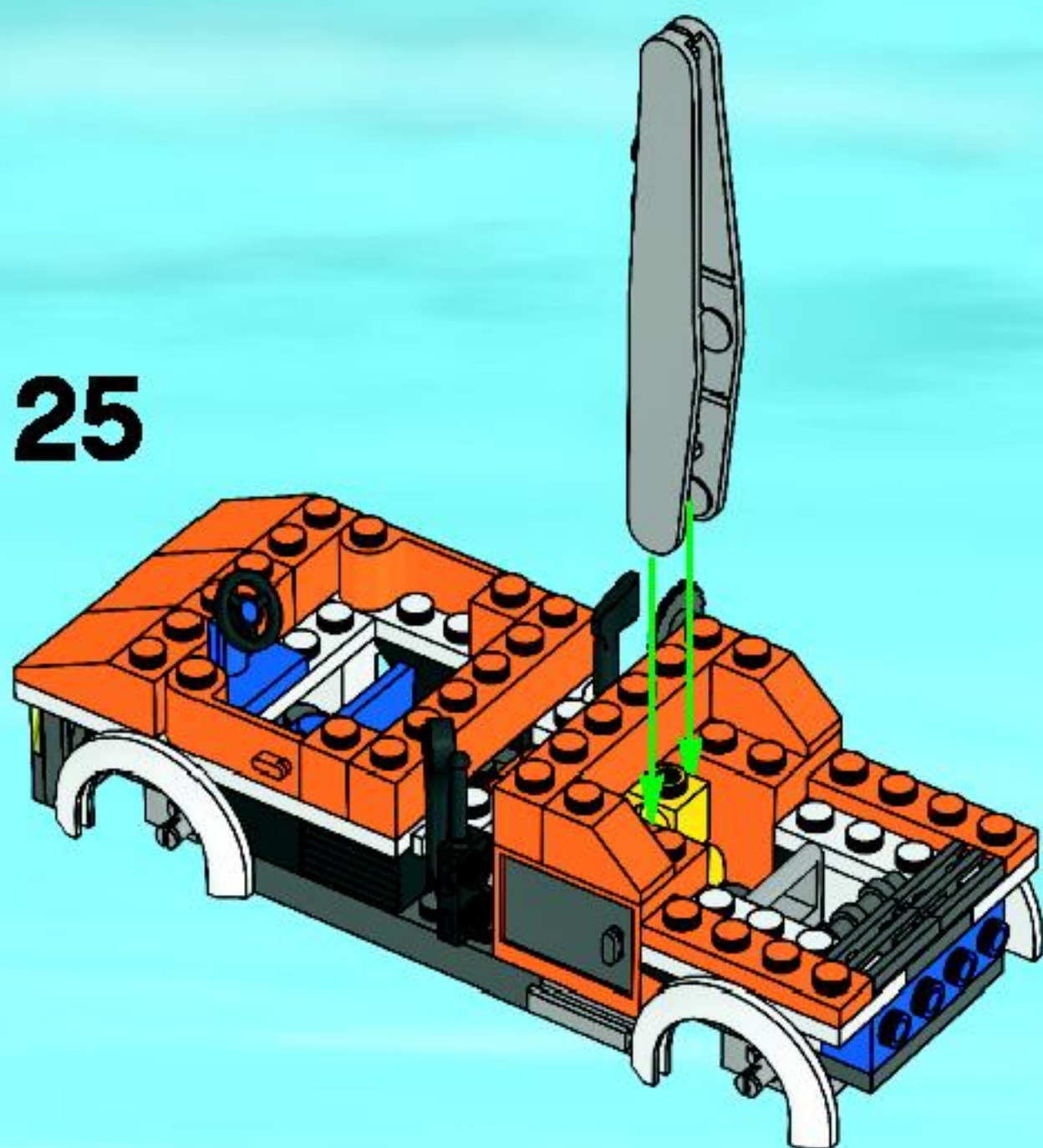

26

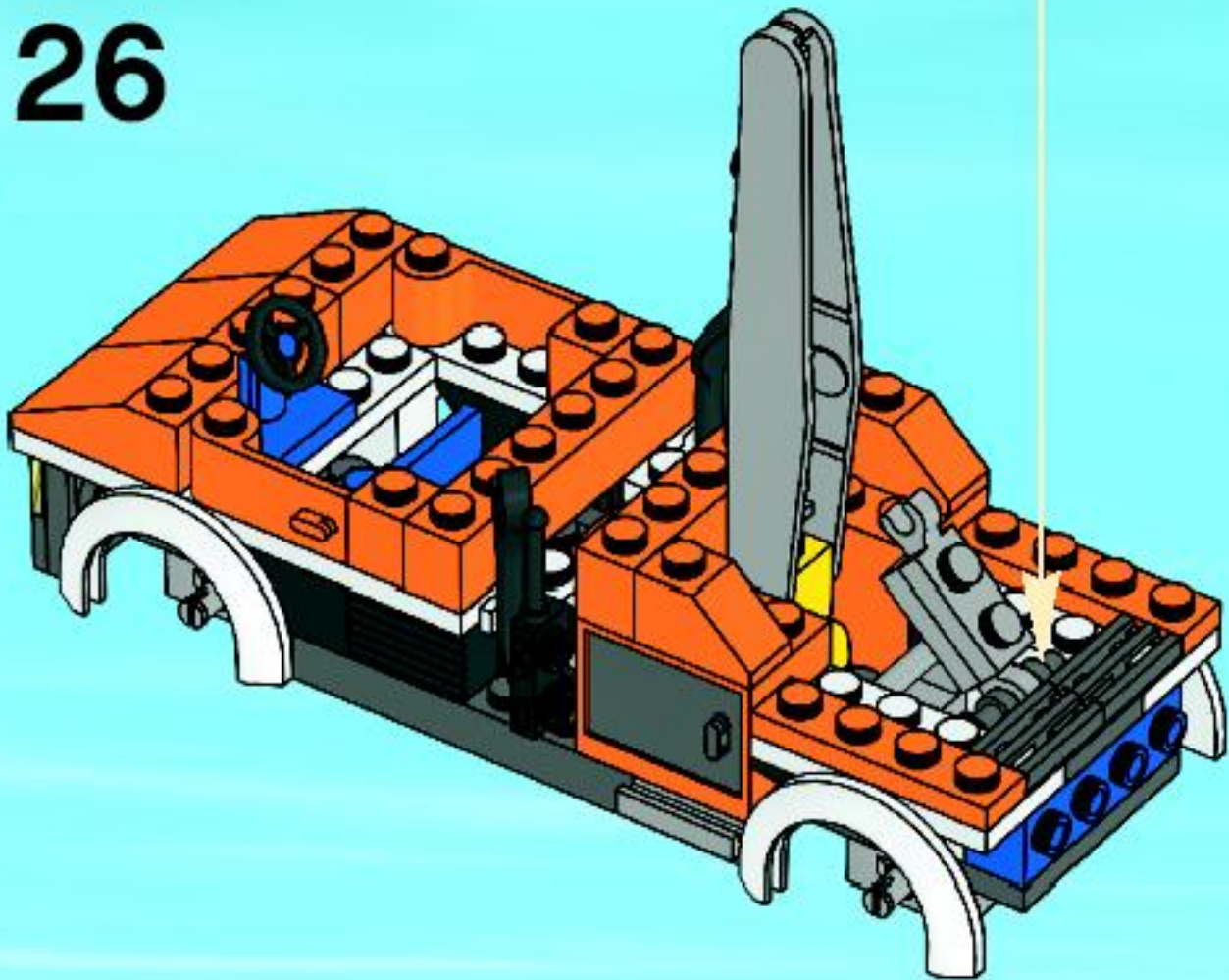
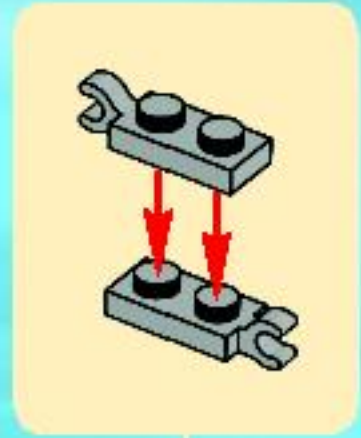

1

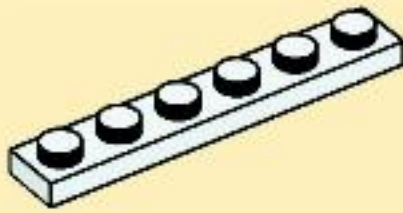

2

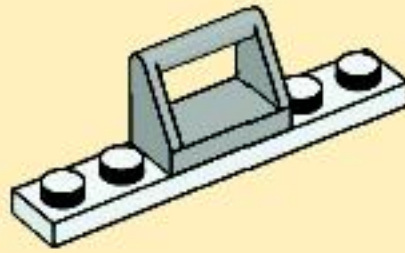

3

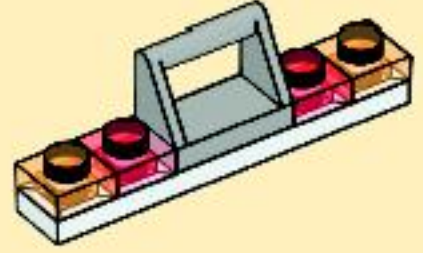

27

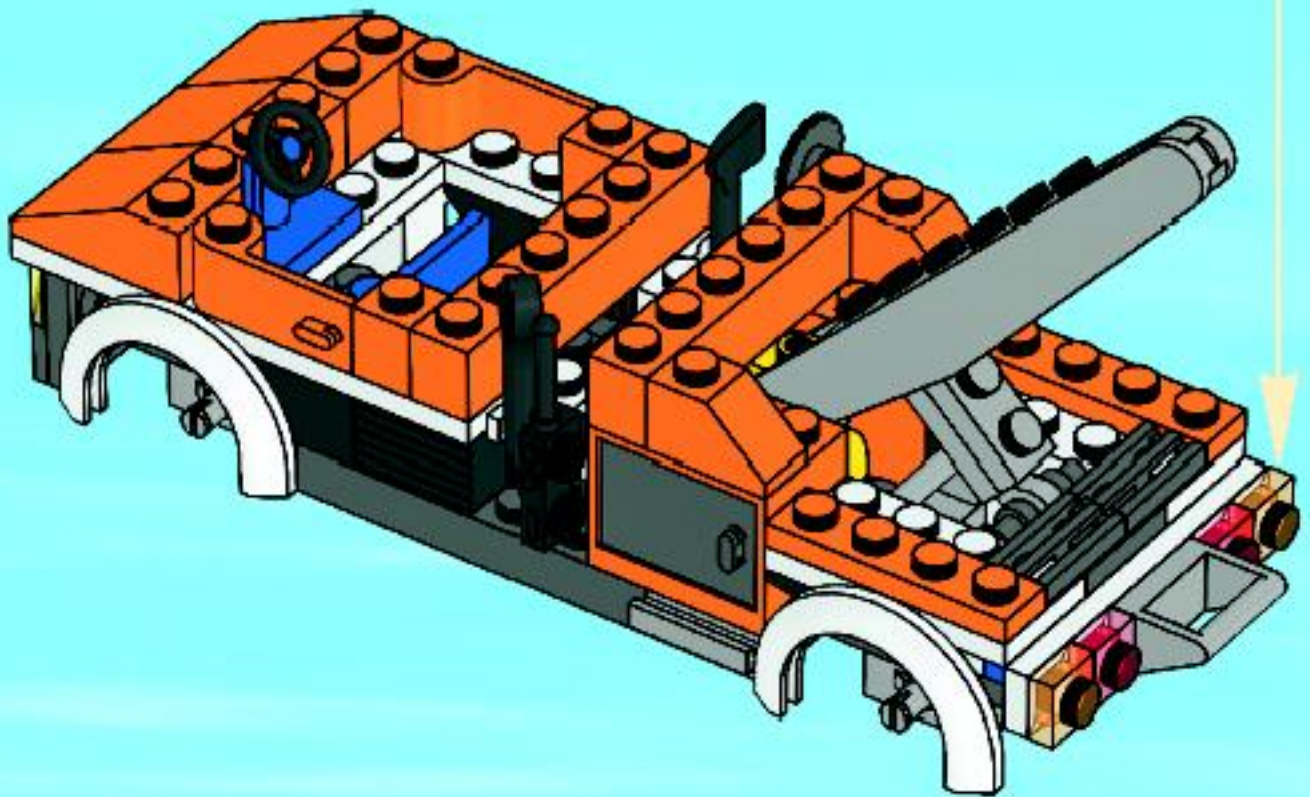



1

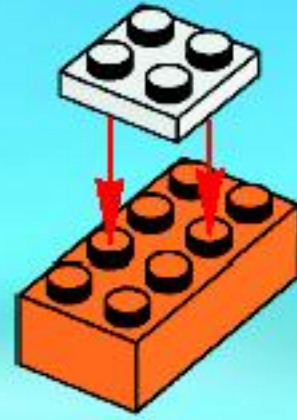

2



3



4

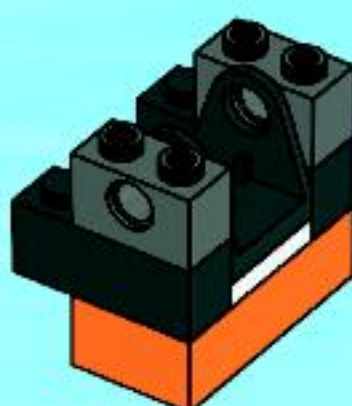

5

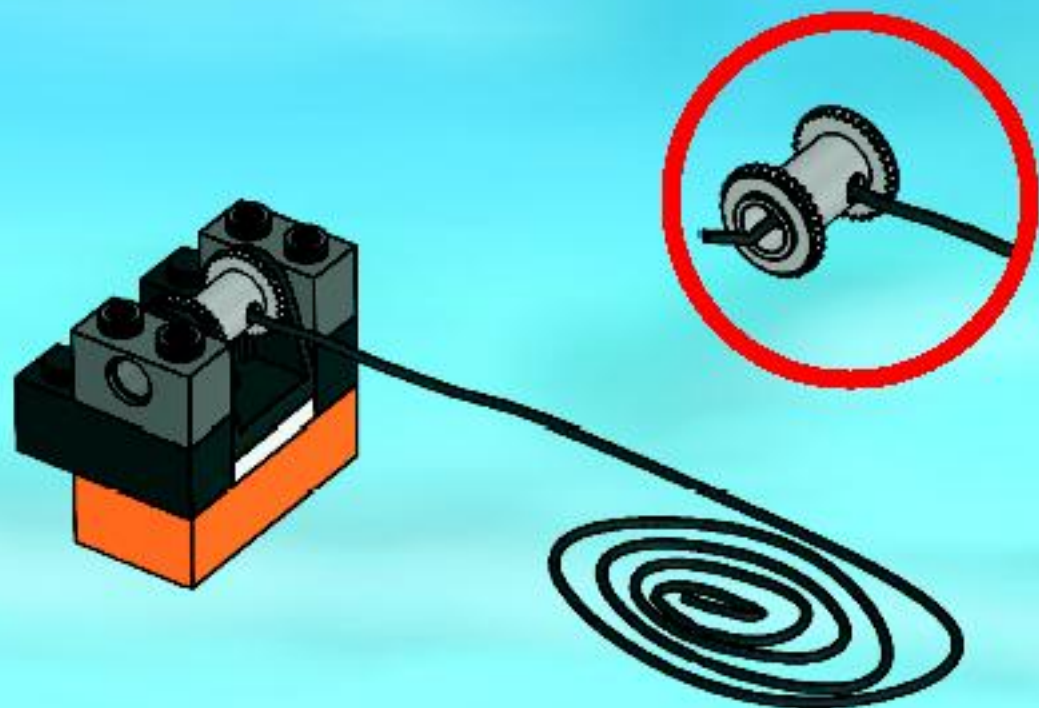

1



2

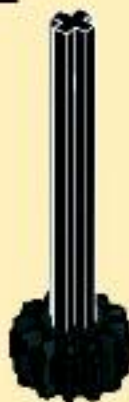

3



6

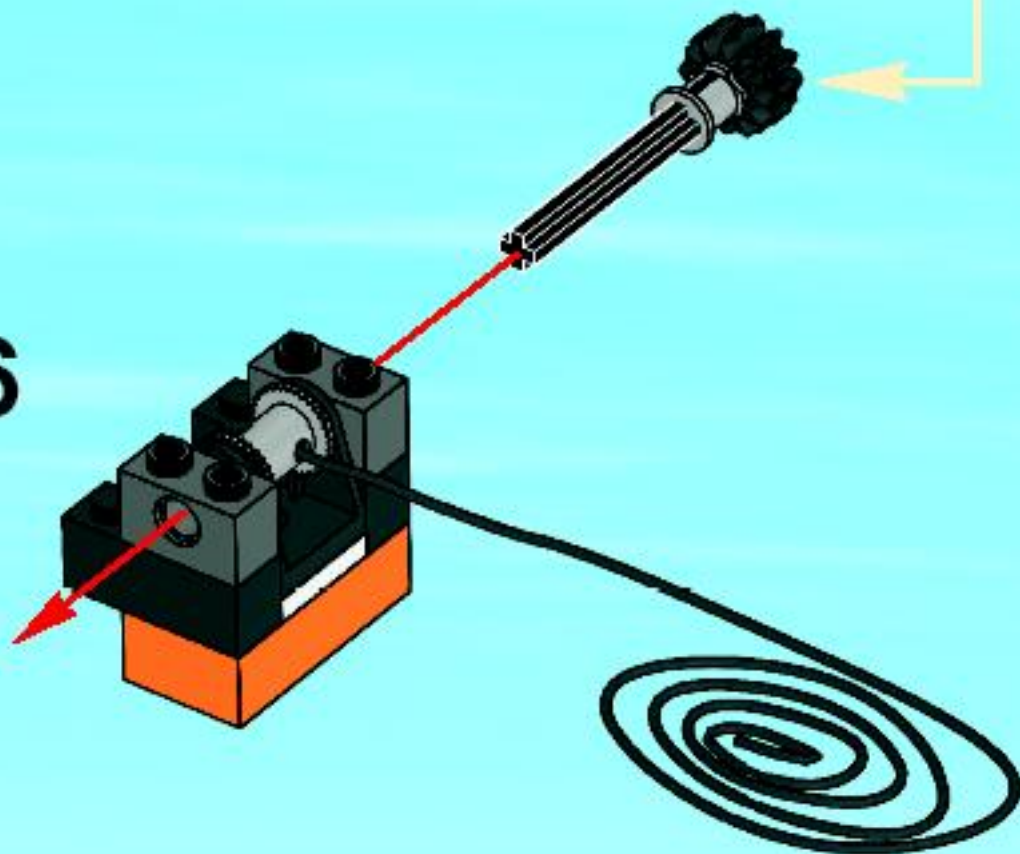

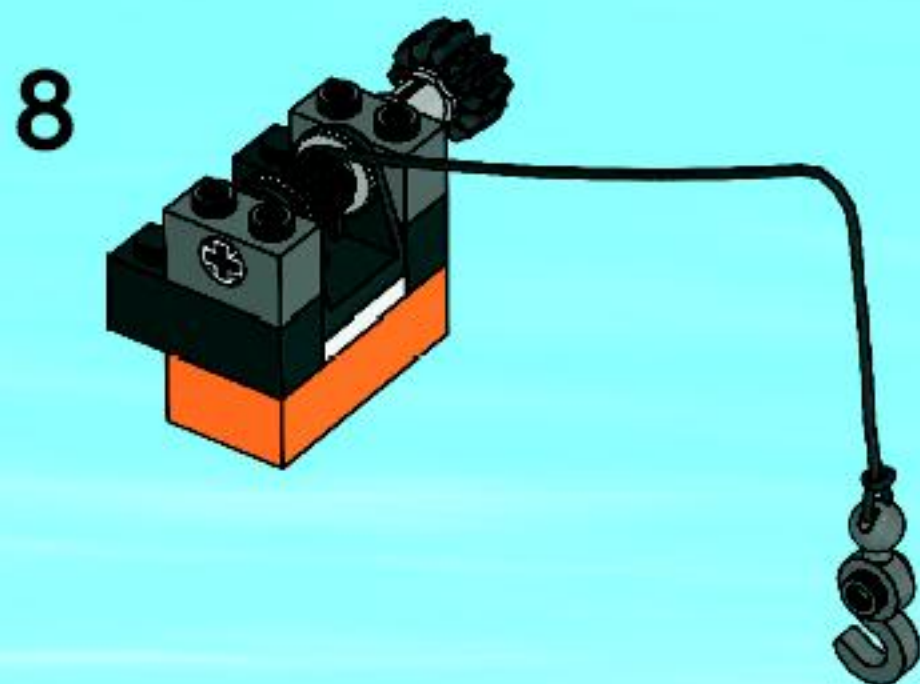
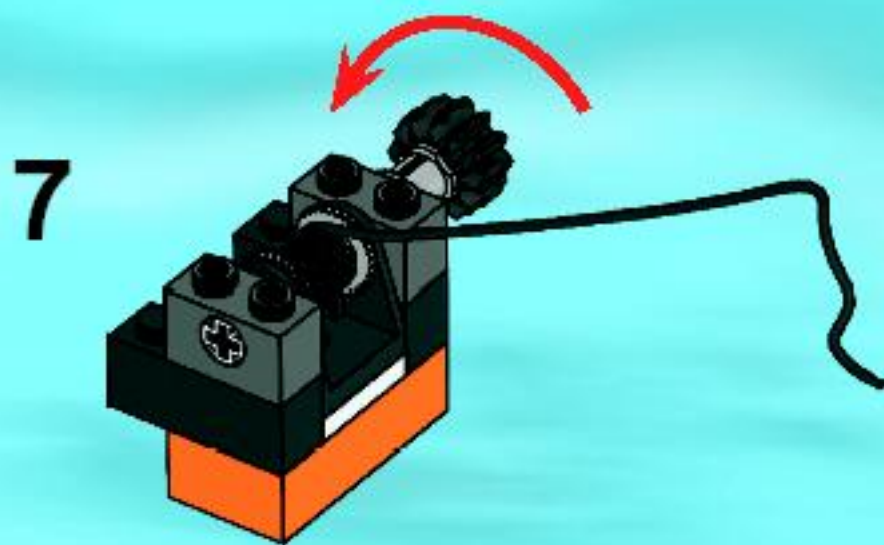

29

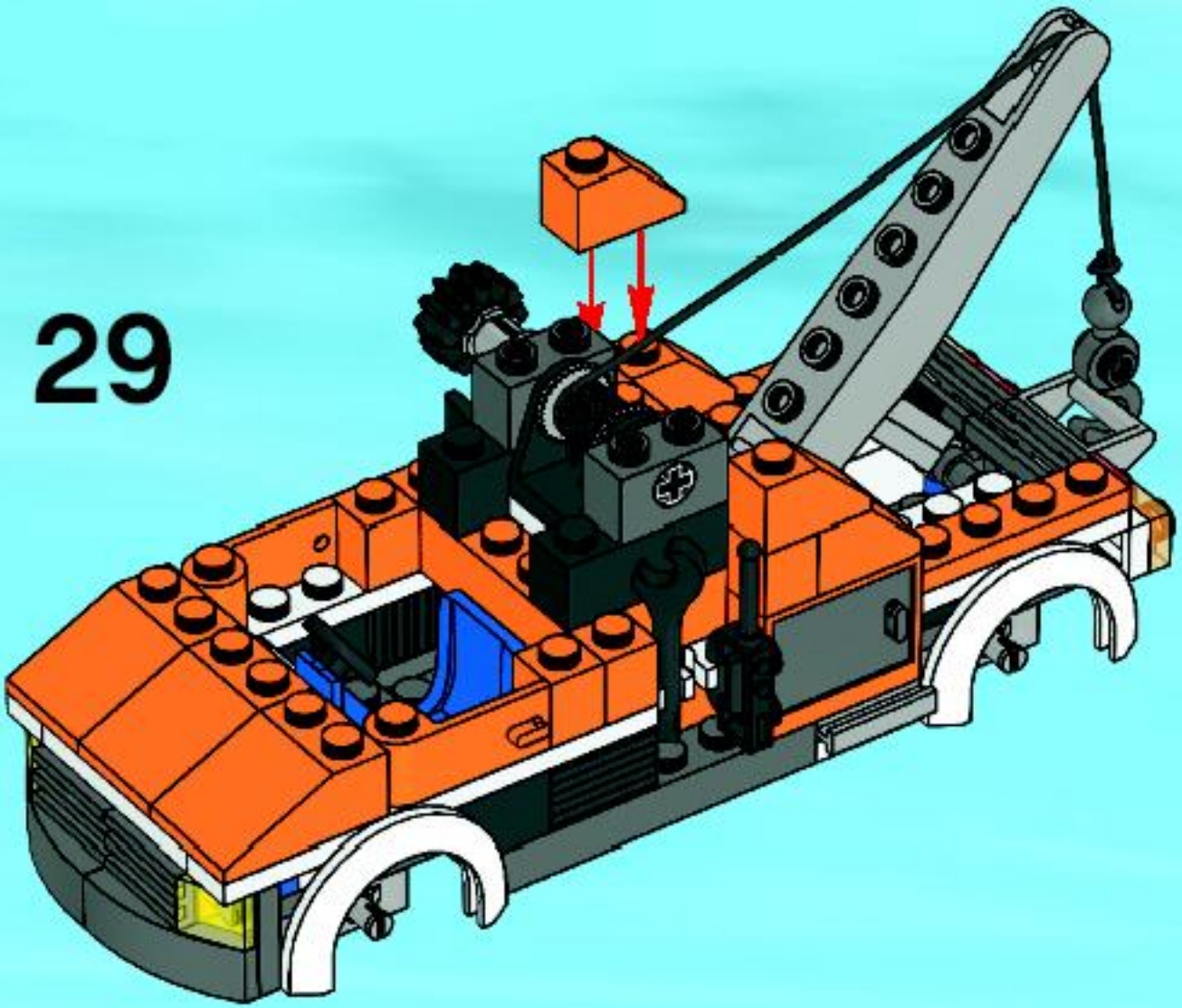



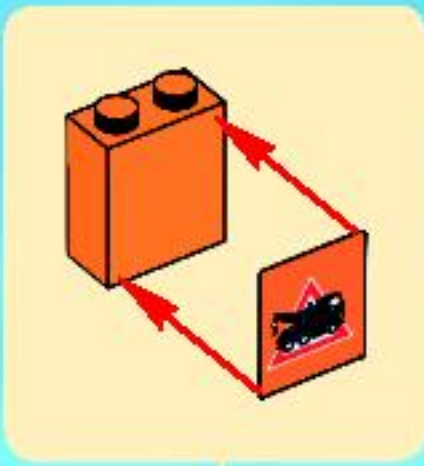

30

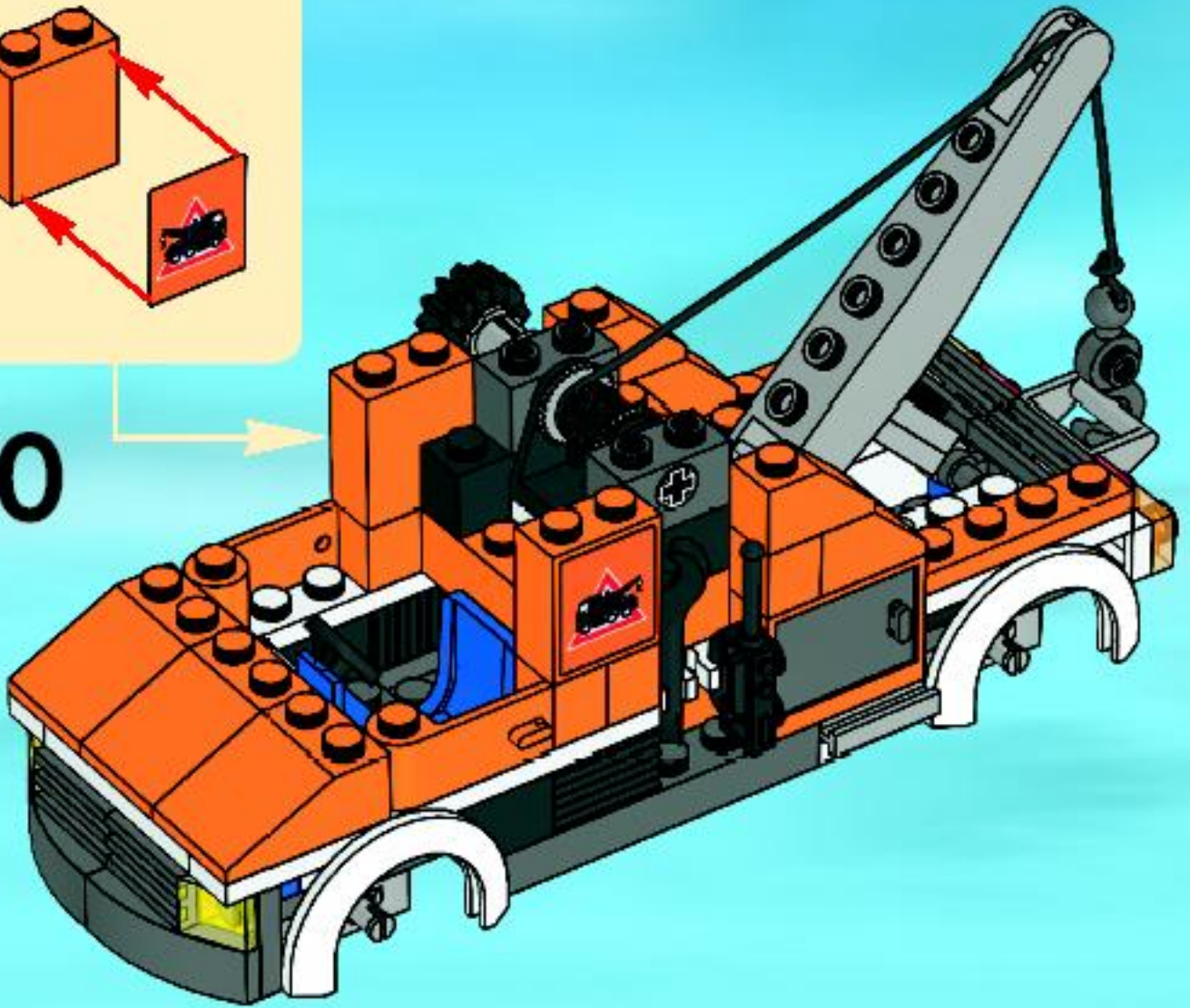

31

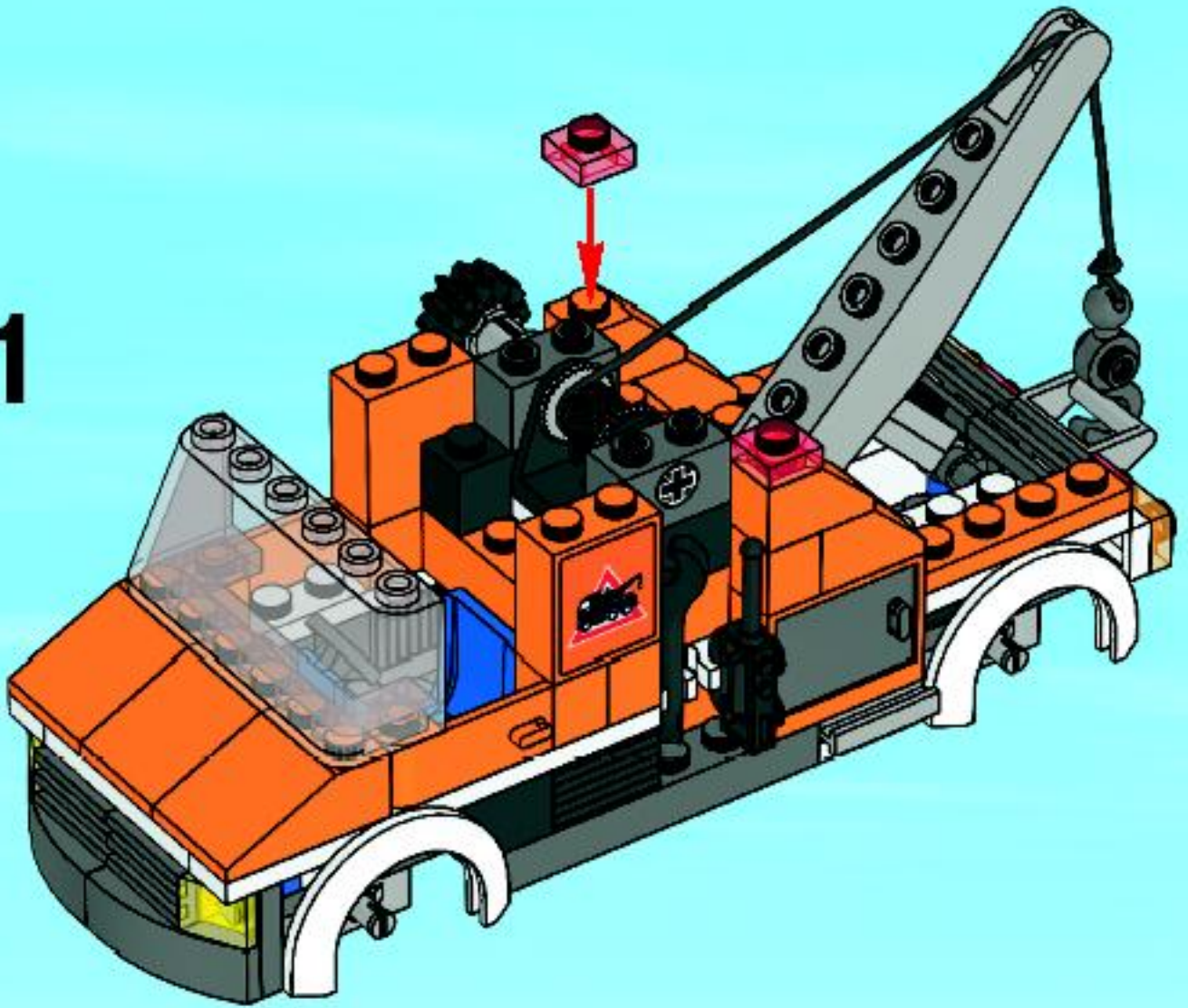

32



1

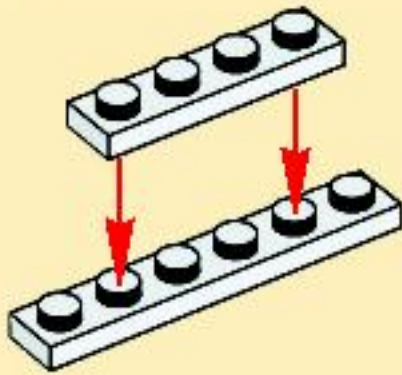

2

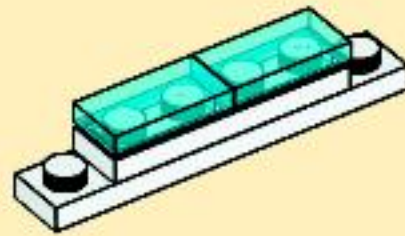

3

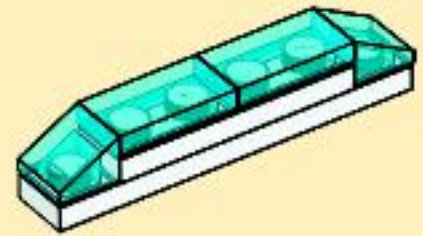

33





4x  
4259940



2x  
4518400



4x  
408501



1x  
371001



2x  
366601



2x  
346001



3x  
302201



2x  
302001

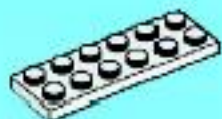

2x  
379501



1x  
4243812



4x  
4170457



2x  
4173805



2x  
4545311



2x  
4189007



2x  
4153827



2x  
4520812



1x  
4545313



1x  
4545315



4x  
4177932



5x  
4118782



1x  
4505118



4x  
4121967



3x  
4121742

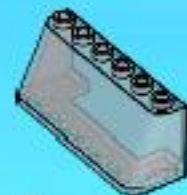

1x  
4173328

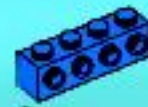

2x  
4212411



1x  
9566



1x  
9341



1x  
448523



1x  
4548877



1x  
407923



1x  
4201615



1x  
4187061



1x  
4194017



2x  
362226



1x  
370626

1x  
4177431

1x  
258426

1x  
383526

2x  
287726

4x  
366526

1x  
400626

1x  
4276318

4x  
4514560

1x  
396226

2x  
4246896

1x  
4212529

1x  
4211080

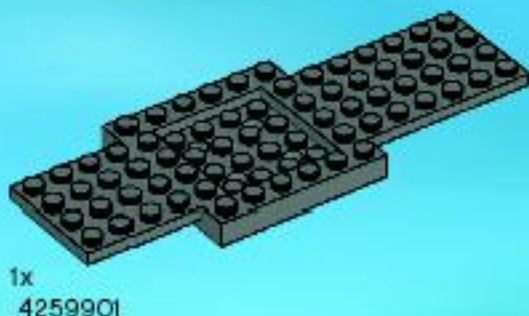

1x  
4259901

2x  
4210811

1x  
4210660

1x  
4211002

4x  
4210631

2x  
4211111

4x  
4211496

1x  
4211622

2x  
4211357

1x  
4211370

1x  
4505354

2x  
4211568

2x  
4535738

4x  
3000841

2x  
4113854

2x  
4244366

2x  
4260942

2x  
4524365

2x  
4542673



Customer Service

Kundenservice

Service Consommateurs

Servicio Al Consumidor

[www.lego.com/service](http://www.lego.com/service) or dial



00800 5346 5555

1-800-422-5346

# LEGO CITY



7642



7641



7639



7638



8402

**FREE! GRATIS! GRATUIT!**



**club**  
MAGAZINE™

**www.LEGOclub.com**



**00800 5346 5555\***



**1-866-534-6258 • 1-877-518-5346**

US & Canada only

Canada seulement

\* FreePhone. Mobile charges may apply. \* Numéro sans Frais. Des Frais peuvent s'appliquer avec les téléphones cellulaires.  
\* Gebührenfrei. Kosten für Anrufe aus Mobilfunknetzen können anfallen. \* Großes telefonsnummer vinní Froska línu.  
\* Det er et gratis nummer, når du ringer fra Posttelefon. \* Telefon gratis, når du ringer fra en Fast telefon.



VISIT THE WORLD'S  
BIGGEST LEGO® SHOP!

**www.LEGOshop.com**



## WIN LEGO® PRODUCTS

Fill out a survey and you might WIN a cool LEGO product  
NO PURCHASE NECESSARY

Open to all residents where not prohibited  
Go to [www.nielsen.dk/LEGO](http://www.nielsen.dk/LEGO) to fill out a survey for a chance to win a LEGO product.

## WIN LEGO® PRODUCTEN

Vul een enquêteformulier in en maak kans op een cool LEGO® product!

Kopen niet nodig  
Iedereen uit landen waar geen enquêteverbod geldt mag deelnemen.

Ga naar [www.nielsen.dk/LEGO](http://www.nielsen.dk/LEGO), vul een enquêteformulier in en maak kans op een LEGO product.

## GEWINNE LEGO® PRODUKTE

Nimm an der Umfrage teil und GEWINNE ein tolles LEGO® Produkt!  
Die Teilnahme am Gewinnspiel führt zu keinerlei Kaufverpflichtungen  
Teilnahme in allen nicht ausgeschlossenen Ländern möglich  
Wir verlosen unter allen Teilnehmern der Umfrage auf [www.nielsen.dk/LEGO](http://www.nielsen.dk/LEGO) LEGO Produkte.

## GAGNE DES PRODUITS LEGO®

Réponds à un questionnaire et tu pourras GAGNER un produit LEGO® très cool !

Aucune obligation d'achat.  
Ouvert à tous les résidents des pays autorisés.  
Visite [www.nielsen.dk/LEGO](http://www.nielsen.dk/LEGO) pour répondre à un questionnaire et avoir une chance de gagner un produit LEGO.

## レゴ®製品を「当てよう」

アンケートに記入して、かっこいいレゴ®製品を当てよう！  
お買い上げの必要はありません。  
禁止されていない限り、すべての皆様にご利用いただけます。  
[www.nielsen.dk/LEGO](http://www.nielsen.dk/LEGO)にアクセスして、アンケートにご記入ください。当選者にはレゴ®製品を差し上げます。



 [www.LEGO.com](http://www.LEGO.com)